

Fixed Displacement Gear Pumps

D/H/HD Series

Catalog HY09-D/H/HD/US



Description	Page No.	
Introduction	3	"HD" Series
General Description	4	Ordering Information..... 24
		Technical Information..... 25-27
"D" Series		Fluid Recommendations 28
Ordering Information.....	5	Instructions for Reversing
Technical Information.....	6-9	Gear Pump Rotation 29
Dimensions	10-13	Offer of Sale 30
Dimensions - Accessories	14	
"H" Series		
Ordering Information.....	15-16	
Technical Information.....	17-20	
Dimensions	21-22	
Dimensions - Shaft Configuration	23	

 **WARNING**

FAILURE OR IMPROPER SELECTION OR IMPROPER USE OF THE PRODUCTS AND/OR SYSTEMS DESCRIBED HEREIN OR RELATED ITEMS CAN CAUSE DEATH, PERSONAL INJURY AND PROPERTY DAMAGE.

This document and other information from Parker Hannifin Corporation, its subsidiaries and authorized distributors provide product and/or system options for further investigation by users having technical expertise. It is important that you analyze all aspects of your application and review the information concerning the product or system in the current product catalog. Due to the variety of operating conditions and applications for these products or systems, the user, through its own analysis and testing, is solely responsible for making the final selection of the products and systems and assuring that all performance, safety and warning requirements of the application are met.

The products described herein, including without limitation, product features, specifications, designs, availability and pricing, are subject to change by Parker Hannifin Corporation and its subsidiaries at any time without notice.

Offer of Sale

The items described in this document are hereby offered for sale by Parker Hannifin Corporation, its subsidiaries or its authorized distributors. This offer and its acceptance are governed by the provisions stated in the "Offer of Sale".

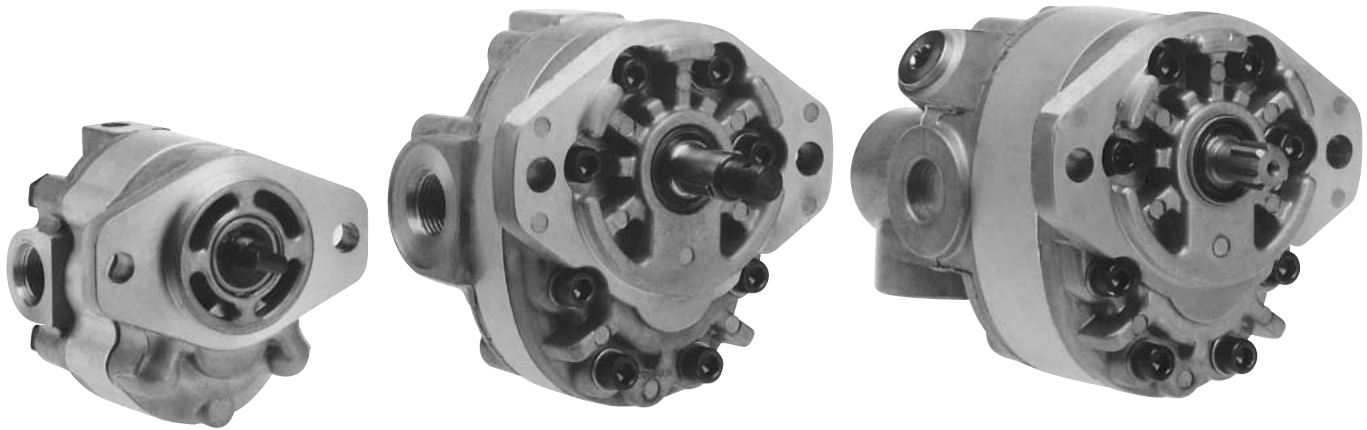

Quick Reference Data Chart

Pump Series	Displacement IN ³ /REV. (CC/REV.)	Pump Delivery @ 1000 RPM In GPM (LPM)	Weight In Pounds (Kg)
D	.114 - .641 (1.87 - 10.50)	.5 - 2.7 (1.9 - 10.2)	2 - 3 (.9 - 1.4)
H	.603 - 2.227 (9.88 - 36.50)	2.5 - 9.3 (9.5 - 35.2)	5 - 7 (2.3 - 3.2)
HD	See above	See above	See above

Features

- Pressure-loaded design
- Efficient, simple design - few moving parts
- Exceptionally compact and lightweight for their capacity
- Efficient at high pressure operation
- Resistant to cavitation effects
- High tolerance to system contamination
- Reliable under cold weather operation
- Sleeve-bearing construction
- Multi-fluid compatibility

Pressure capabilities

- D - to 2500 PSI (172 Bar) continuous
- H - to 2500 PSI (172 Bar) continuous
- HD - to 2500 PSI (172 Bar) continuous

Controls

- Optional built-in relief valve on "D" series
- Optional built-in relief valve on "H" series
- Optional built-in relief valve, and flow divider on "H" series
- Special controls (Consult Technical Services)

Speed capabilities

- D - to 4000 RPM
- H - to 4000 RPM
- HD - to 4000 RPM

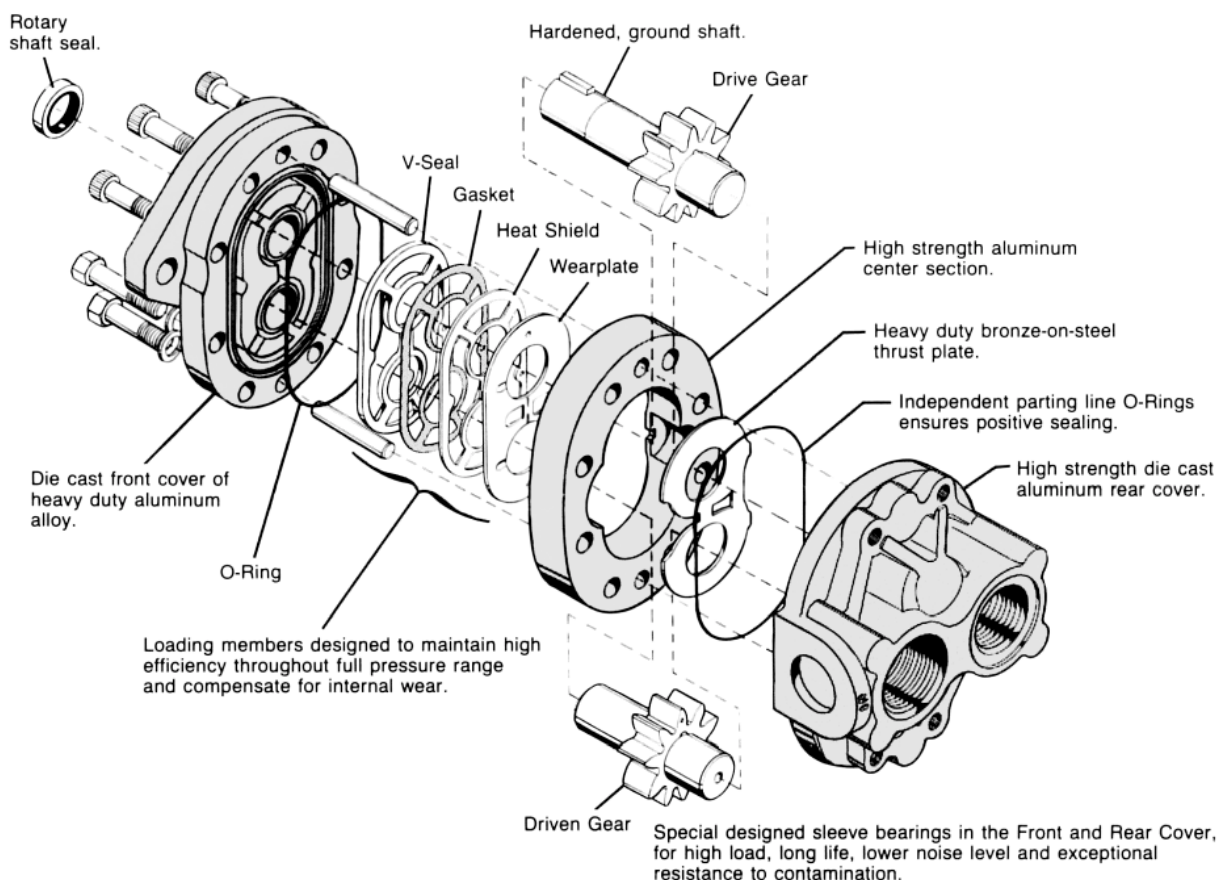

A Parker pressure-loaded gear pump consists of two, intermeshing, hardened-steel, precision-ground gear assemblies. These precision gears are enclosed by a high-strength, die-cast aluminum front cover, back cover and a high-yield, strength-extruded aluminum center section.

Gear assemblies consist of one drive gear, shrink-fitted on a precision-ground and polished drive shaft. This shaft extends outside the pump to permit coupling to an external prime mover. The second gear, being the driven gear, is also shrink-fitted on a precision-ground and polished driven shaft. Retaining rings, which are installed in grooves provided on the shaft, ensure that the gears will not move axially, and a key keeps the drive gear from moving radially.

A lip-type, shaft seal is provided at the drive shaft to prevent external leakage of pump fluid. The sealing lip in contact with the fluid is spring-loaded. Vent passages within the housings and driven shaft communicate pump inlet pressure to the rotary seal area, thus imposing the lowest possible pressure at the rotary seal for extended seal life.

The phenolic heat shield, backup gasket, and molded rubber seal form chambers behind the steel-backed bronze wearplate. These chambers are connected either to inlet or discharge pressure. Discharge pressure, acting within the chambers, axially loads and deflects the wear plate toward the gear faces to take up gear side clearances. This pressure-loading on the wear plate increases pump efficiency by reducing internal leakage to a minimum, providing longer pump life.

Pump rotation is dependent upon the proper orientation of the heat shield, backup gasket, and rubber seal in the front cover housing, the center section and rear cover, respectively.

Pumping action is achieved by connecting the pump drive shaft to a prime mover, and rotating the gears away from the inlet port. Rotation causes the gear mesh to increase on the inlet side and decrease on the outlet (pressure) side.

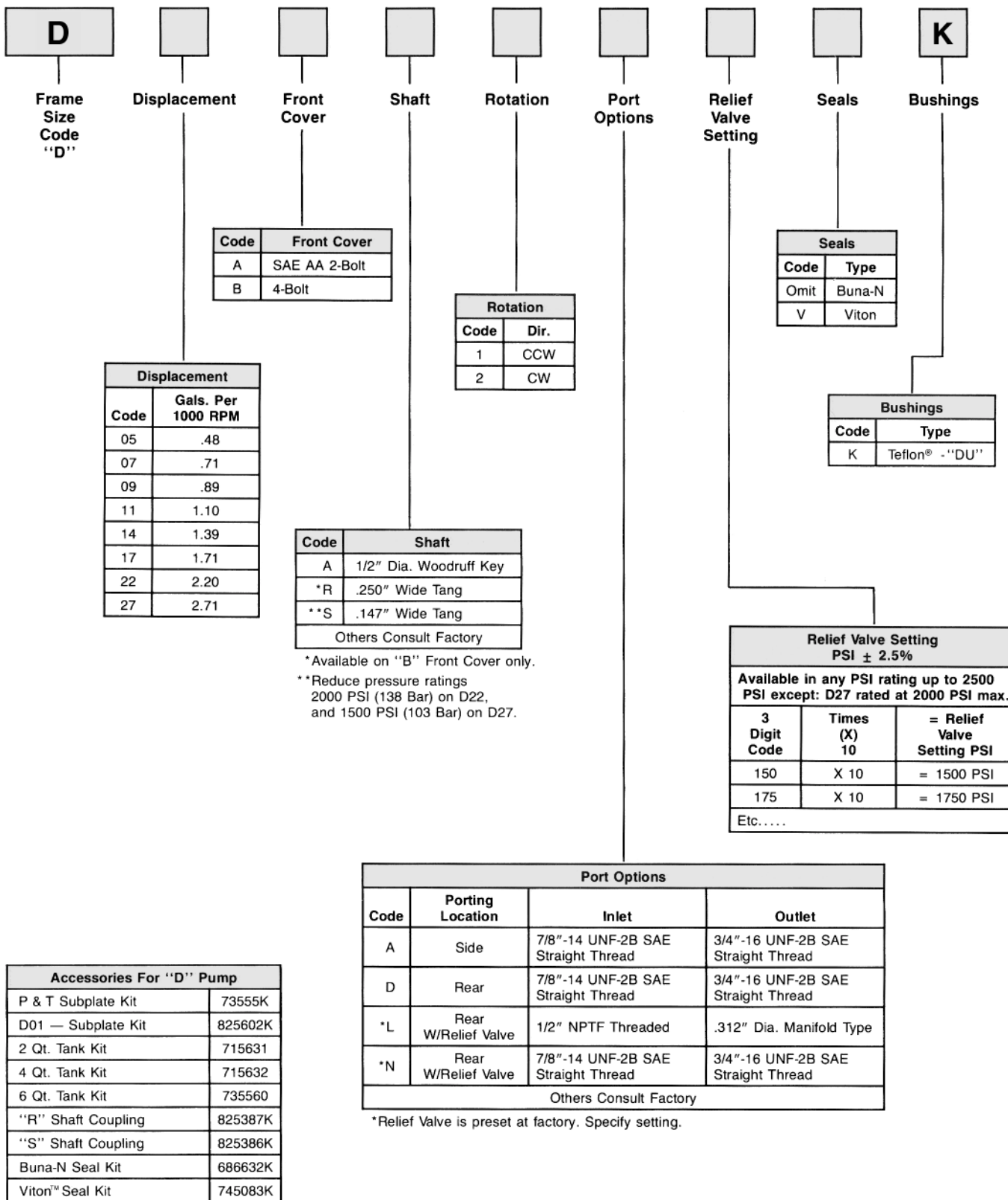

Performance Data

Series D Fixed Displacement, Pressure-Loaded Gear Pump

Features

- Pressure-loaded design
- Efficient, simple design - few moving parts
- Exceptionally compact and lightweight for their capacity
- Efficient at high pressure operation
- Resistant to cavitation effects
- High tolerance to system contamination
- Reliable under cold weather operation
- Sleeve-bearing construction
- Multi-fluid compatibility

Controls

- Optional built-in relief valve
- Consult factory for special controls

Specifications

Flow Ratings:

.5 GPM (1.9 LPM) to 2.7 GPM (10.2 LPM)
(At 1000 RPM) See next page for additional flow data.

Pressure Ratings:

D05 thru D22 - 2500 PSI (172 Bar) continuous
D27 - 2000 PSI (138 Bar) continuous

Speed Ratings:

D05 thru D22 - 500 to 4000 RPM
D27 - 3000 RPM

Mounting:

SAE-AA - 2-Bolt Flange
4-Bolt Flange

Housing Material:

Die-Cast Aluminum

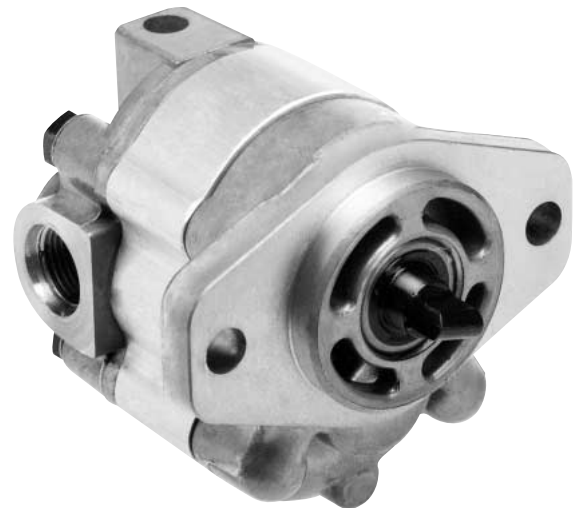

Schematic Symbol

(Basic Pump)



Installation Data

Inlet Conditions:

- 10 in. hg. max. vacuum condition
(At 1800 RPM)
- 5 in. hg. max. vacuum condition
(At max. RPM)
- 20 PSI (1.4 Bar) max. positive pressure

Operating Temperature Range:

- 40°F to 185°F
(-40°C to 85°C)

Filtration:

Maintain SAE Class 4

Installation Note:

See page 28 for specific recommendations pertaining to system cleanliness, fluids, start-up, inlet conditions, shaft alignment, and other important factors relative to the proper installation and use of these pumps.

Performance Data

Data Based on 100 SSU
 Viscosity Fluids at 120°F (49°C)

Flow in Gallons Per Minute – GPM (LPM)

Pump Model	Displacement IN ³ (CC/REV.)	RPM	100 PSI (6.9 Bar)	1000 PSI (69 Bar)	1500 PSI (103 Bar)	2000 PSI (138 Bar)	2500 PSI (172 Bar)
D05	.114 (1.87)	1200	.58 (2.20)	.48 (1.82)	.42 (1.59)	.37 (1.40)	.32 (1.21)
		1800	.87 (3.30)	.77 (2.92)	.71 (2.69)	.66 (2.50)	.61 (2.31)
		3600	1.73 (6.56)	1.65 (6.25)	1.61 (6.10)	1.56 (5.91)	1.52 (5.76)
D07	.168 (2.76)	1200	.85 (3.22)	.73 (2.77)	.68 (2.58)	.62 (2.35)	.56 (2.12)
		1800	1.28 (4.85)	1.16 (4.40)	1.10 (4.17)	1.05 (3.98)	.99 (3.75)
		3600	2.56 (9.70)	2.47 (9.36)	2.42 (9.17)	2.37 (8.98)	2.33 (8.83)
D09	.210 (3.45)	1200	1.06 (4.02)	.94 (3.56)	.87 (3.30)	.81 (3.07)	.75 (2.84)
		1800	1.60 (6.06)	1.48 (5.61)	1.41 (5.34)	1.35 (5.12)	1.29 (4.89)
		3600	3.19 (12.09)	3.09 (11.71)	3.04 (11.52)	2.99 (11.33)	2.94 (11.14)
D11	.262 (4.29)	1200	1.32 (5.00)	1.19 (4.51)	1.12 (4.24)	1.06 (4.02)	.99 (3.75)
		1800	1.99 (7.54)	1.86 (7.05)	1.79 (6.78)	1.73 (6.56)	1.66 (6.29)
		3600	3.97 (15.05)	3.86 (14.63)	3.81 (14.44)	3.76 (14.25)	3.70 (14.02)
D14	.329 (5.38)	1200	1.66 (6.29)	1.52 (5.76)	1.44 (5.46)	1.37 (5.19)	1.30 (4.92)
		1800	2.49 (9.44)	2.35 (8.91)	2.27 (8.60)	2.20 (8.34)	2.13 (8.07)
		3600	4.99 (18.91)	4.88 (18.50)	4.82 (18.27)	4.76 (18.04)	4.70 (17.81)
D17	.404 (6.62)	1200	2.04 (7.73)	1.88 (7.13)	1.80 (6.82)	1.72 (6.52)	1.64 (6.22)
		1800	3.07 (11.64)	2.91 (11.03)	2.83 (10.73)	2.75 (10.42)	2.67 (10.12)
		3600	6.14 (23.27)	6.01 (22.78)	5.95 (22.55)	5.88 (22.29)	5.82 (22.06)
D22	.522 (8.55)	1200	2.64 (10.00)	2.46 (9.32)	2.37 (8.98)	2.28 (8.64)	2.19 (8.30)
		1800	3.97 (15.05)	3.79 (14.36)	3.70 (14.02)	3.61 (13.68)	3.52 (13.34)
		3600	7.93 (30.05)	7.79 (29.52)	7.71 (29.22)	7.64 (28.96)	7.57 (28.69)
D27	.641 (10.50)	1200	3.25 (12.32)	3.05 (11.56)	2.95 (11.18)	2.85 (10.80)	---
		1800	4.87 (18.46)	4.67 (17.70)	4.57 (17.32)	4.47 (16.94)	---
		3000	8.12 (30.77)	7.96 (30.17)	7.88 (29.86)	7.80 (29.56)	---

Performance Data

**Based On Oil Temperature of 120°F (49°C)
 (100 SSU) Atmospheric Inlet**

D05/D07 Horsepower/Speed

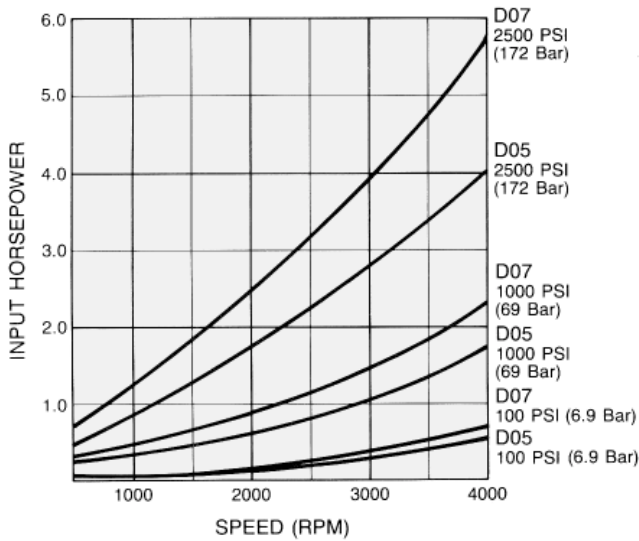

D05/D07 Flow/Speed

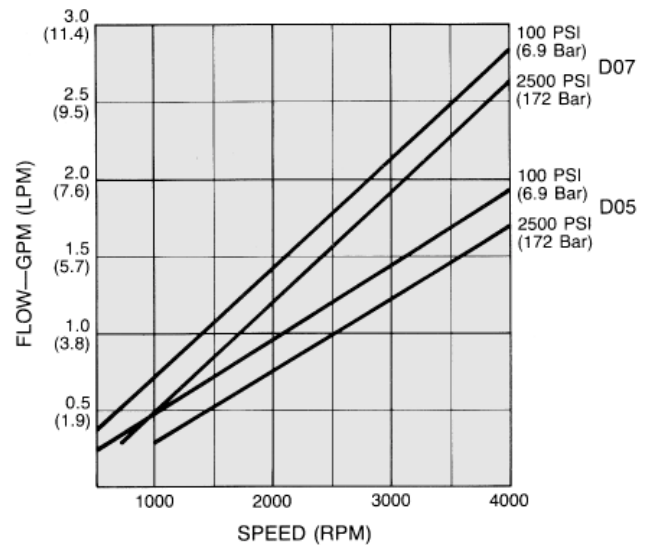

D09/D11 Horsepower/Speed

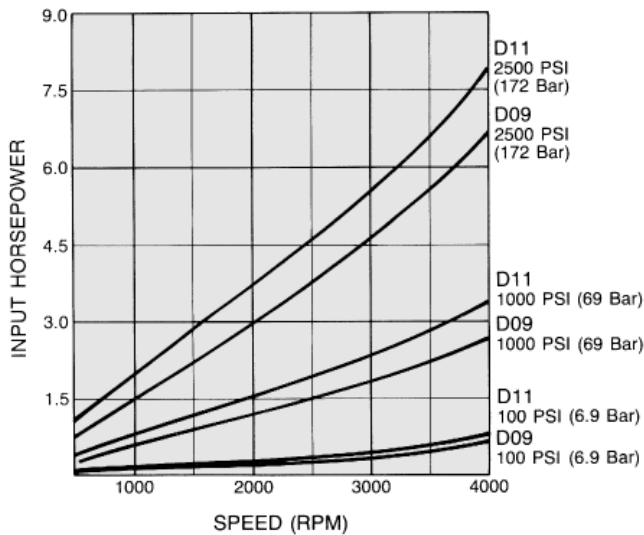

D09/D11 Flow/Speed

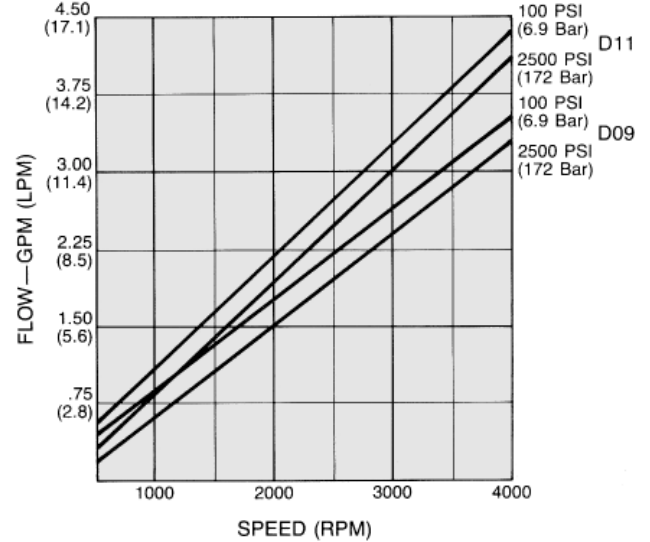

Performance Data

**Based On Oil Temperature of 120°F (49°C)
 (100 SSU) Atmospheric Inlet**

D14/D17 Horsepower/Speed

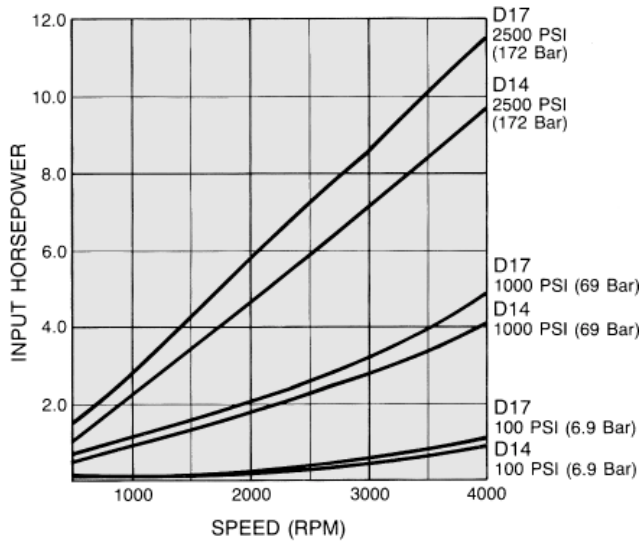

D14/D17 Flow/Speed

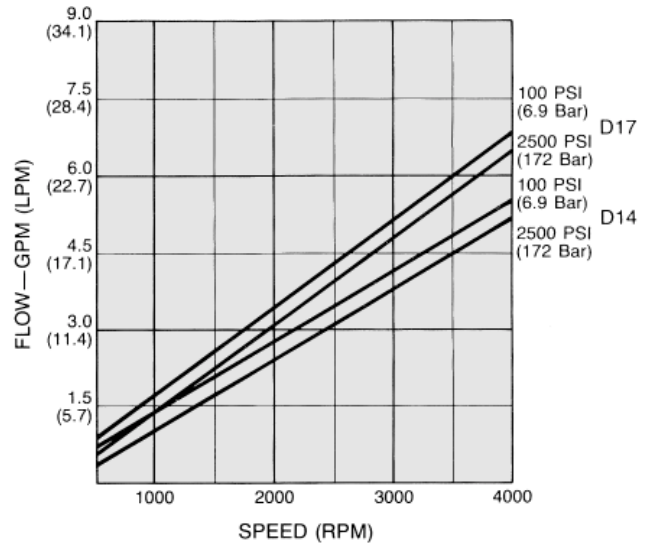

D22/D27 Horsepower/Speed

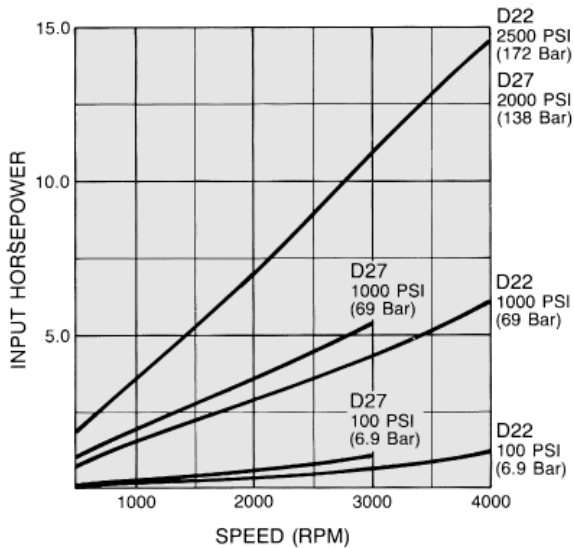

D22/D27 Flow/Speed

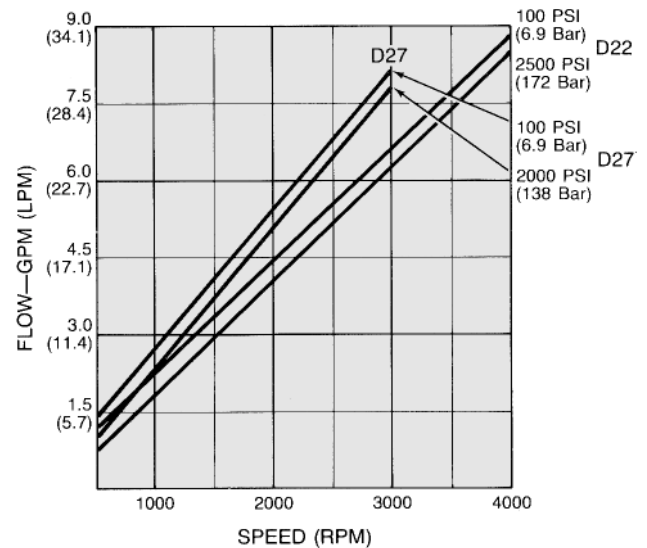

Dimensions – 2-Bolt Mounting

Clockwise rotation and “A” shaft shown
 (Port locations reverse for CCW rotation)

Dimensions: Inches (mm)

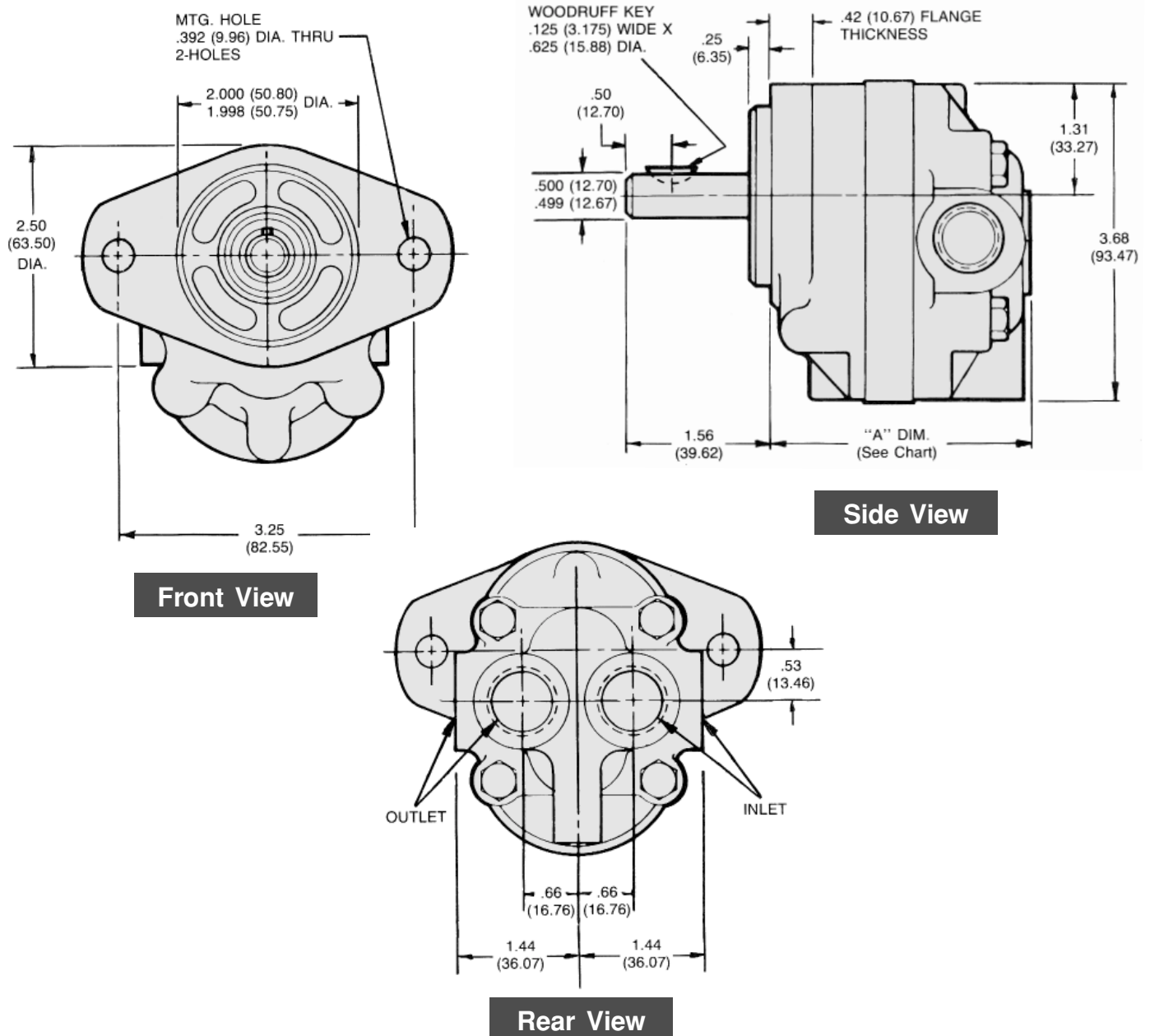

“A” Dimensions: Inches (mm)

D05	D07	D09	D11	D14	D17	D22	D27
2.48 (62.99)	2.57 (65.28)	2.64 (67.06)	2.72 (69.09)	2.83 (71.88)	2.96 (75.18)	3.15 (80.01)	3.34 (84.84)

Dimensions – 4-Bolt Mounting

Clockwise rotation and “A” shaft shown
 (Port locations reverse for CCW rotation.)

Dimensions: Inches (mm)

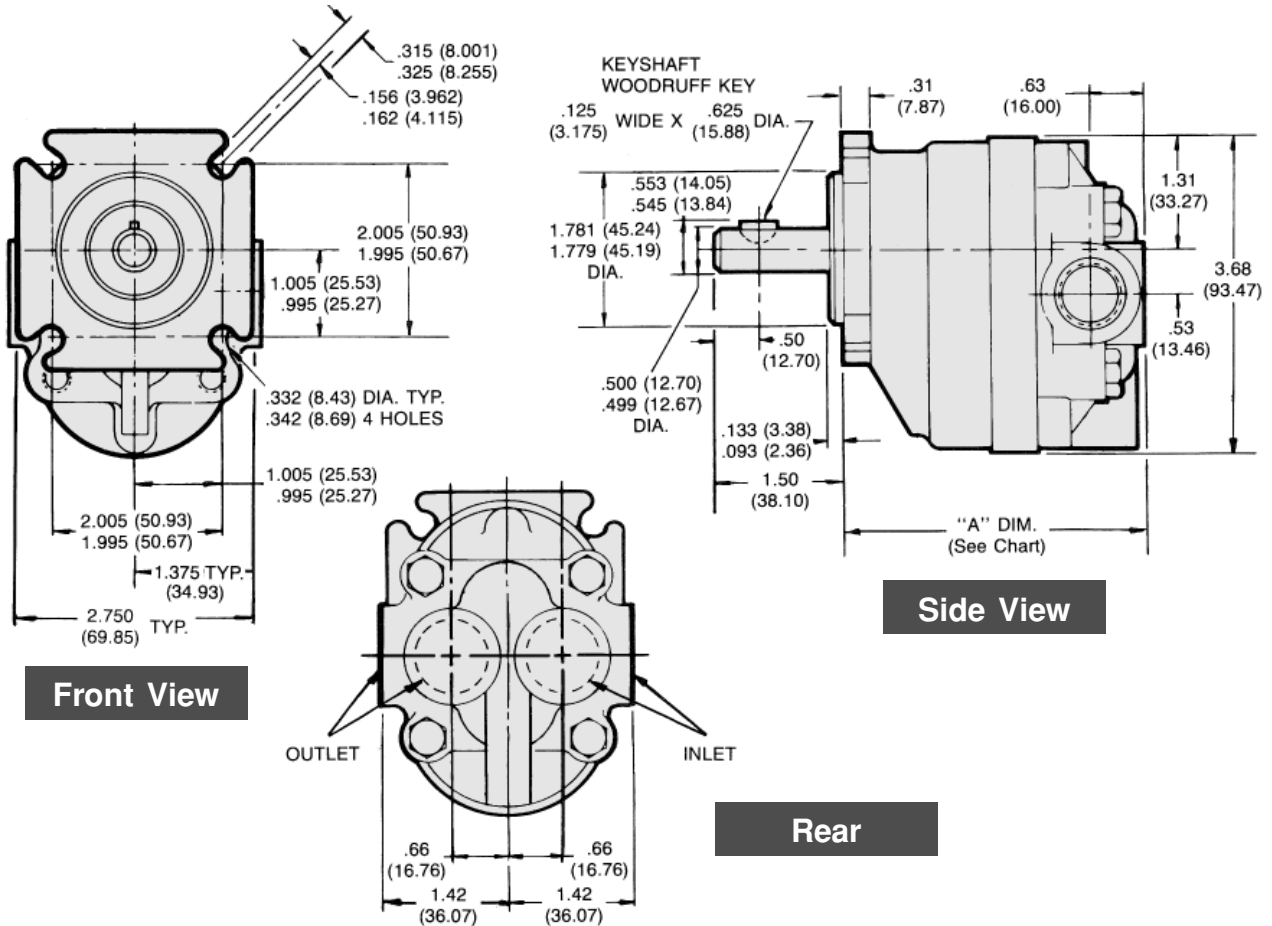

“A” Dimensions: Inches (mm)

D05	D07	D09	D11	D14	D17	D22	D27
3.22 (81.79)	3.31 (84.07)	3.38 (85.85)	3.47 (88.14)	3.58 (90.93)	3.70 (93.98)	3.90 (99.06)	4.09 (103.89)

“S” Tang-end Shaft Option – For Use With 4-Bolt Mounting

Primarily used to direct-couple to electric motor drive.

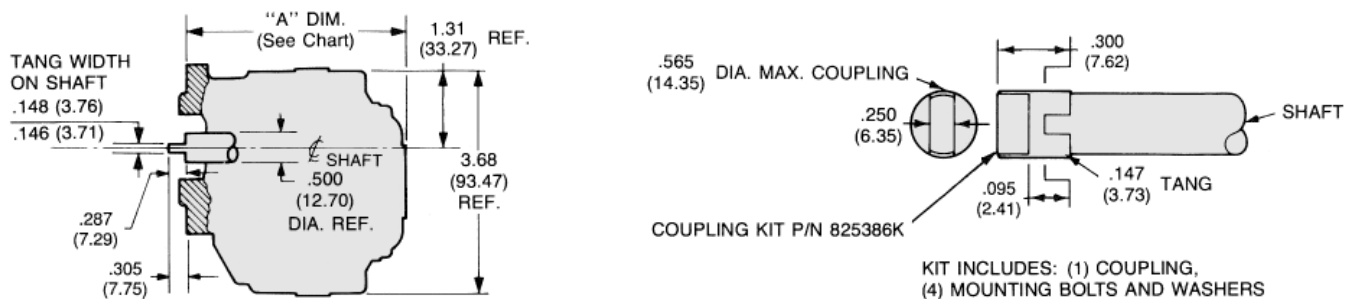

Dimensions – 2-Bolt Mounting
(With "L" Back Cover For Tank Mounting)

Clockwise rotation and "A" shaft shown
 (Pump mounting flange opposite side of back cover centerline for CW rotation.)

Dimensions: Inches (mm)

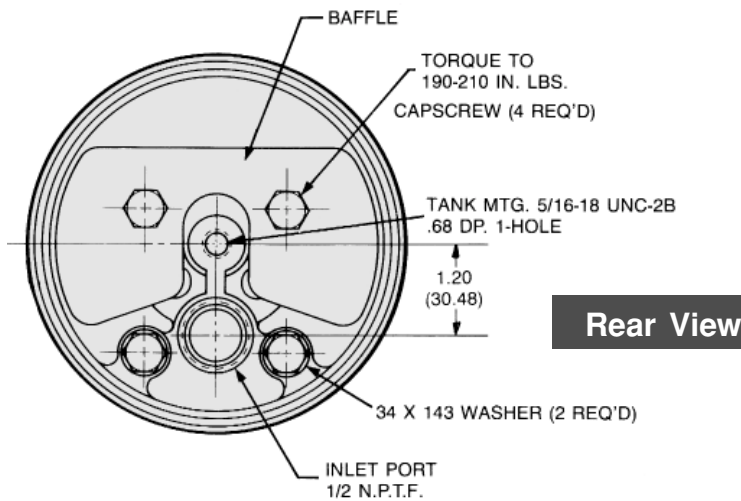
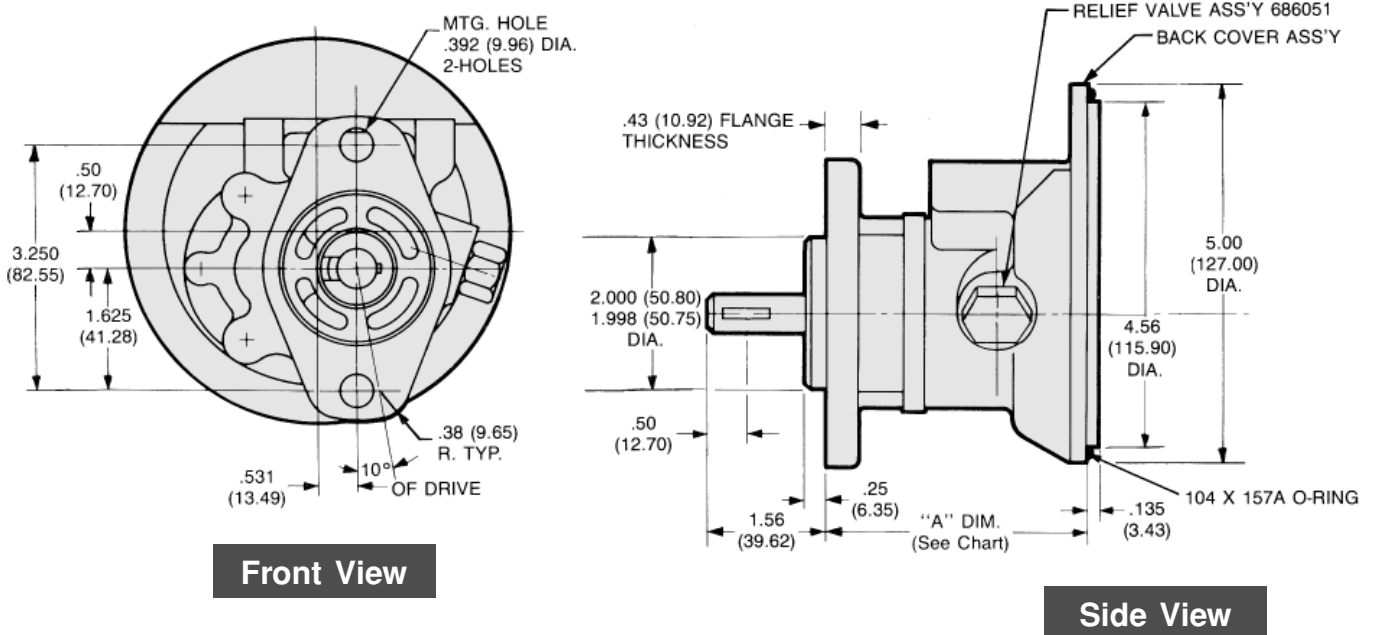

"A" Dimensions: Inches (mm)

D05	D07	D09	D11	D14	D17	D22	D27
3.39 (86.11)	3.48 (88.39)	3.55 (90.17)	3.64 (92.46)	3.75 (95.25)	3.87 (98.30)	4.06 (103.12)	4.26 (108.20)

**Dimensions – 4-Bolt Mounting
 (With "L" Back Cover For Tank Mounting)**

Clockwise rotation and "A" shaft shown
 (Pump mounting flange opposite side of back cover
 centerline for CW rotation.)

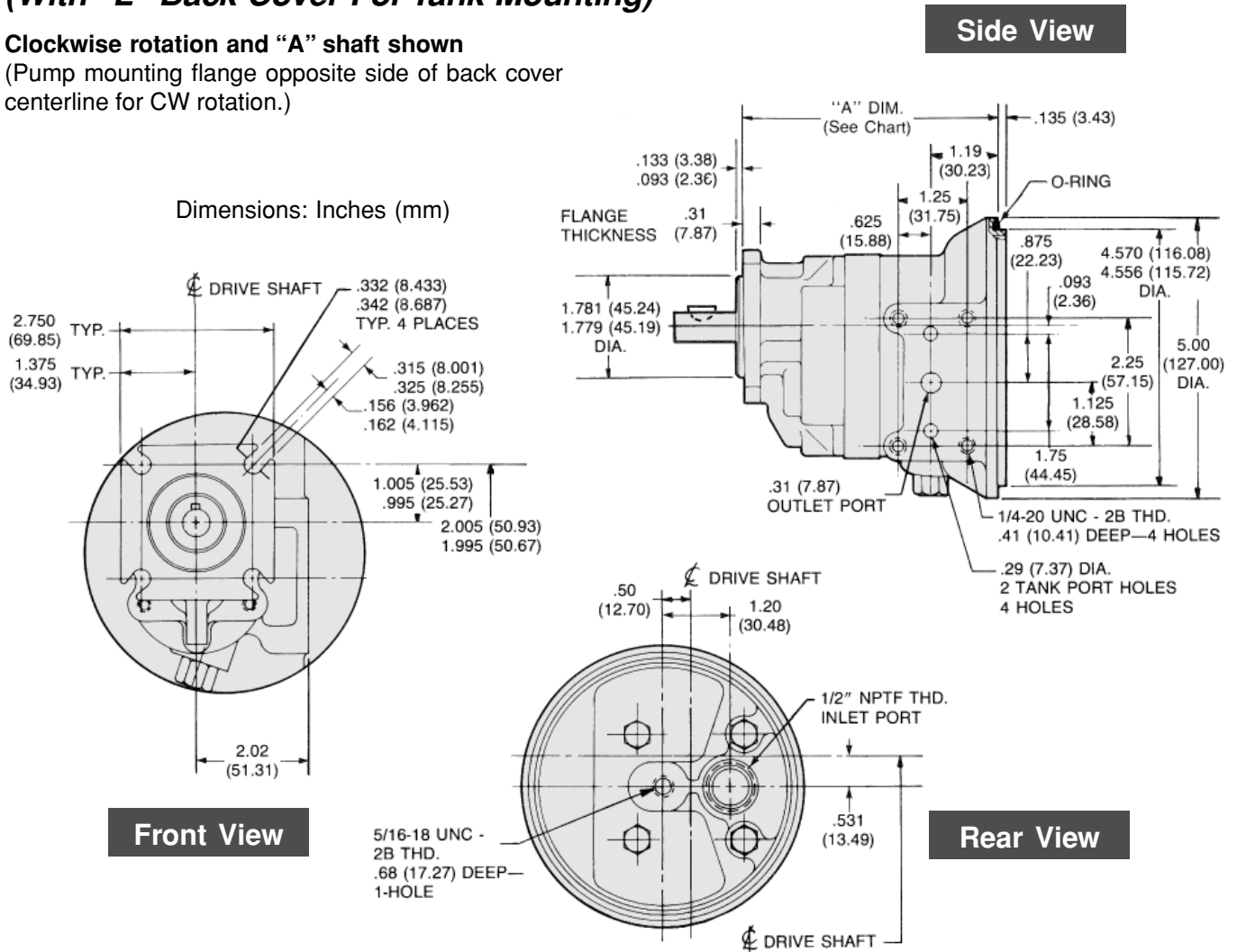

"A" Dimensions: Inches (mm)

D05	D07	D09	D11	D14	D17	D22	D27
4.14 (105.16)	4.23 (107.44)	4.30 (109.22)	4.39 (111.51)	4.50 (114.30)	4.62 (117.35)	4.81 (122.17)	5.01 (127.25)

"B" Tang-end Shaft Option – For Use With 4-Bolt Mounting

Primarily used to direct-couple to electric motor drives.

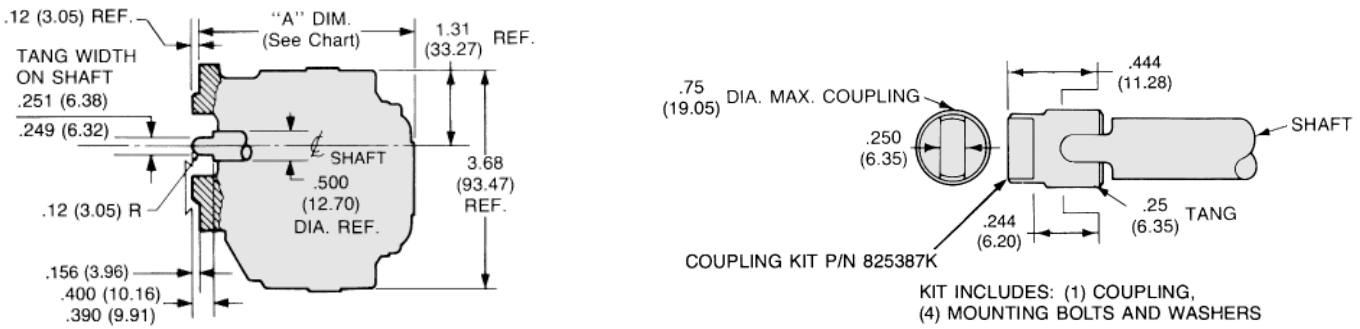

Dimensions – Accessories For “L” Back Cover Pump

Sub-plate for supply, return and gage ports –
 Kit no. 735555K

Dimensions: Inches (mm)

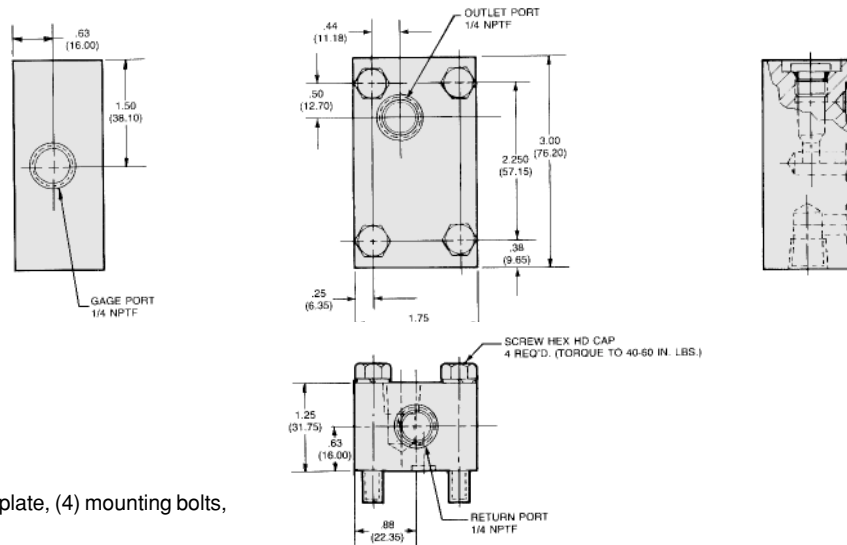

Note: Kit includes (1) sub-plate, (4) mounting bolts, (3) O-rings, (1) plug.

Sub-Plate For Mounting (NFPA D01) Directional Control Valve – Kit No. 825602K

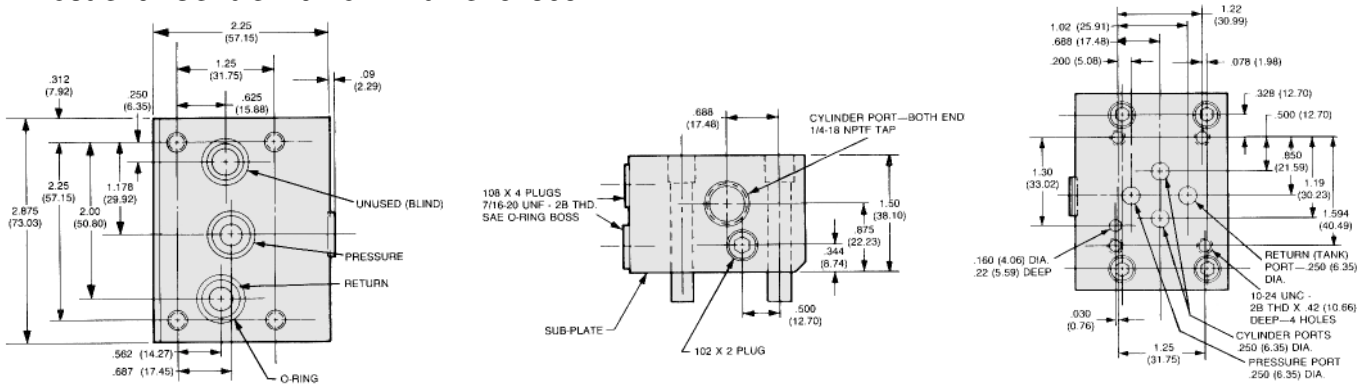

Note: Kit includes (1) sub-plate, (4) mounting bolts, (3) O-rings, (1) plug.

Tanks (Hydraulic Reservoir)

2-Quart Capacity Tank - Kit No. 715631

"B" Dimension 4.67 (118.62) inches

4-Quart Capacity Tank - Kit No. 715632

"B" Dimension 10.17 (258.32) inches

6-Quart Capacity Tank - Kit No. 735560

"B" Dimension 14.17 (359.92) inches

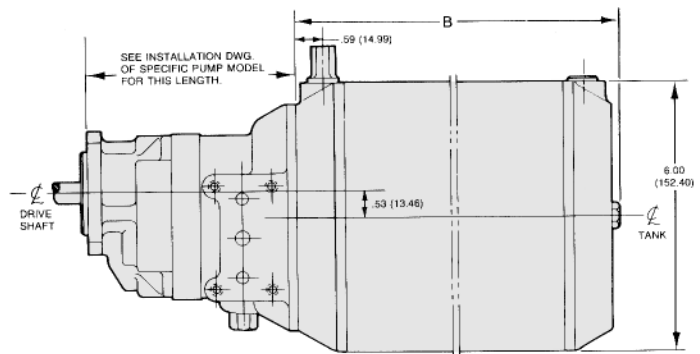

Note: Kit includes- (1) reservoir assembly, (1) suction strainer, (1) filler cap.

Series H Standard Pumps

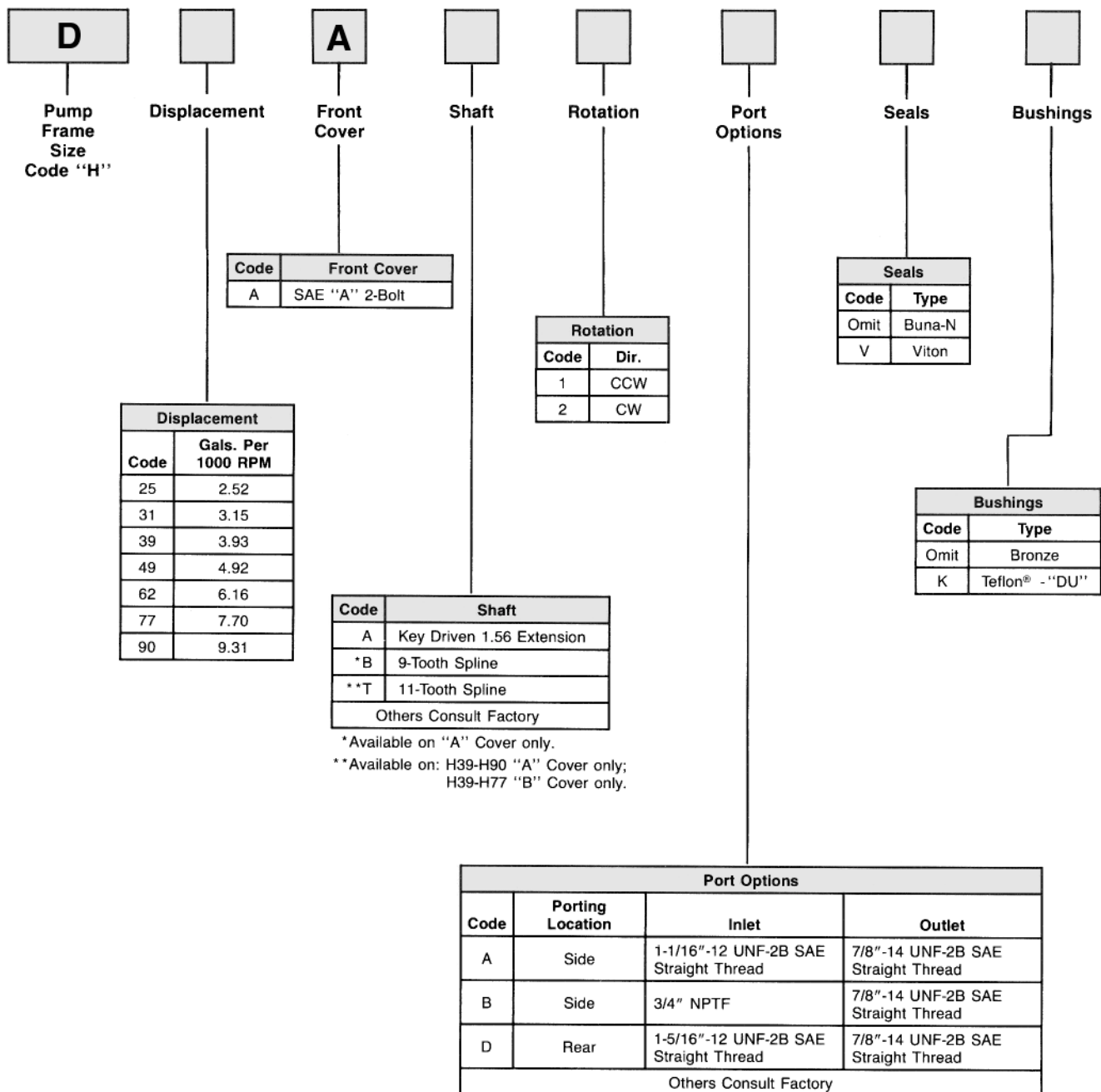

Buna-N Replacement Seal Kit: Order Part No. 706024K

Viton™ Replacement Seal Kit: Order Part No. 745100K

Series H Standard Pumps

Note: Primarily used on "on-road" power steering pump applications.

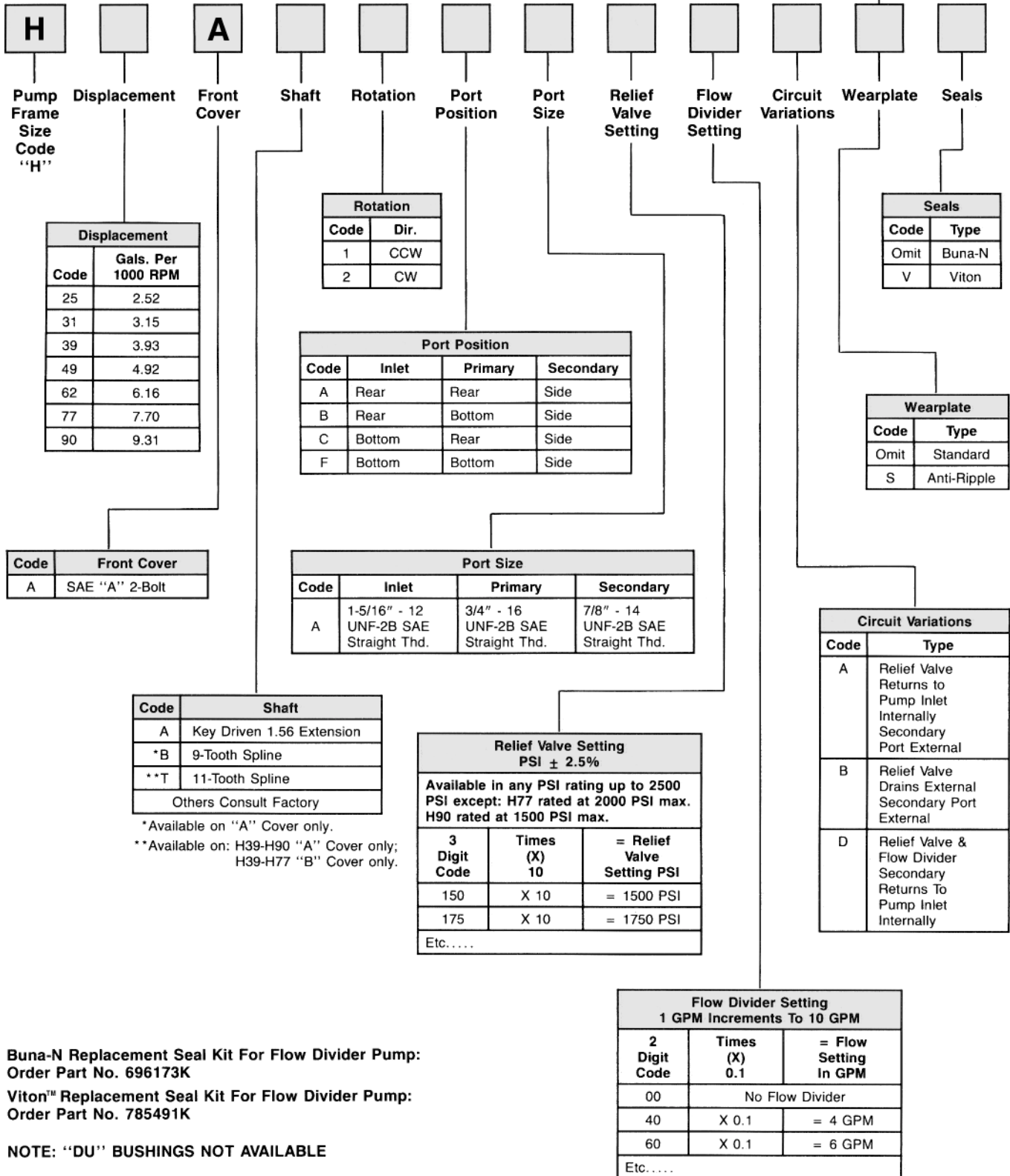

Buna-N Replacement Seal Kit For Flow Divider Pump:
 Order Part No. 696173K

Viton™ Replacement Seal Kit For Flow Divider Pump:
 Order Part No. 785491K

NOTE: "DU" BUSHINGS NOT AVAILABLE



Performance Data

Series H Fixed Displacement, Pressure-Loaded Gear Pump

Features

- Pressure-loaded design
- Efficient, simple design - few moving parts
- Exceptionally compact and lightweight for their capacity
- Efficient at high-pressure operation
- Resistant to cavitation effects
- High tolerance to system contamination
- Reliable under cold weather operation
- Sleeve-bearing construction
- Multi-fluid compatibility

Controls

- Optional built-in relief valve
- Optional built-in relief valve and flow divider
- Special controls (Consult Technical Services)

Specifications

Flow Ratings:

2.5 GPM (9.5 LPM) to 9.3 GPM (35.2 LPM)
(At 1000 RPM) See next page for additional flow data

Pressure Ratings:

H25 thru H62 - 2500 PSI (172 Bar) continuous
H77 - 2000 PSI (138 Bar) continuous
H90 - 1500 PSI (103 Bar) continuous

Speed Ratings:

H25 thru H49 - 500 to 4000 RPM
H62, H77, H90 - 3600 RPM

Mounting:

SAE-A - 2-Bolt Flange
Optional SAE-A - 2-Bolt Flange
Extended Front Cover

Housing Material:

Die-Cast Aluminum

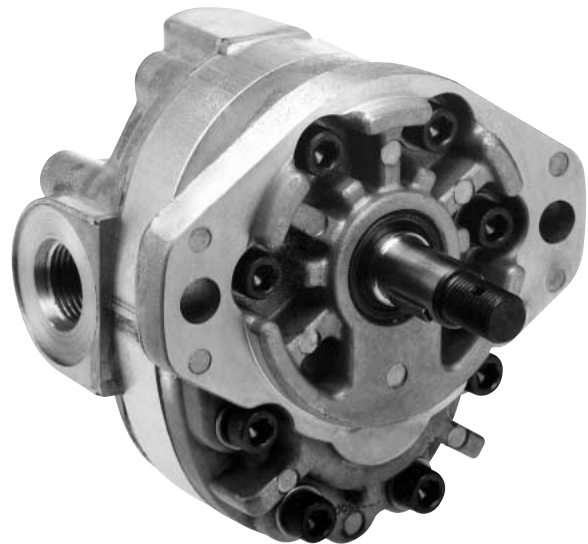

Schematic Symbol

(Basic Pump)



Installation Data

Inlet Conditions:

10 in. hg. max. vacuum condition (at 1800 RPM)
5 in. hg. max. vacuum condition (at max. RPM)
20 PSI (1.4 Bar) max. positive pressure

Operating Temperature Range:

-40°F to 185°F (-40°C to 85°C)

Filtration:

Maintain SAE Class 4

Installation Note:

See page 28 for specific recommendations pertaining to system cleanliness, fluids, start-up, inlet conditions, shaft alignment, and other important factors relative to the proper installation and use of these pumps.

Performance Data

Data Based on 100 SSU
 Viscosity Fluids at 120°F (49°C)

Flow In Gallons Per Minute — GPM (LPM)

Pump Model	Displacement IN ³ (CC/REV.)	RPM	100 PSI (6.9 Bar)	1000 PSI (69 Bar)	1500 PSI (103 Bar)	2000 PSI (138 Bar)	2500 PSI (172 Bar)
H25	.603 (9.88)	1200	3.02 (11.45)	2.84 (10.76)	2.75 (10.42)	2.66 (10.08)	2.57 (9.74)
		1800	4.54 (17.21)	4.35 (16.49)	4.26 (16.15)	4.17 (15.80)	4.09 (15.50)
		3600	9.07 (34.38)	8.93 (33.84)	8.85 (33.54)	8.78 (33.28)	8.70 (32.97)
H31	.754 (12.35)	1200	3.78 (14.33)	3.58 (13.57)	3.49 (13.23)	3.40 (12.89)	3.30 (12.50)
		1800	5.67 (21.49)	5.48 (20.77)	5.38 (20.39)	5.28 (20.01)	5.19 (19.67)
		3600	11.34 (42.98)	11.19 (42.41)	11.11 (42.11)	11.03 (41.80)	10.96 (41.54)
H39	.942 (15.44)	1200	4.72 (17.89)	4.51 (17.09)	4.41 (16.71)	4.30 (16.30)	4.20 (15.92)
		1800	7.08 (26.83)	6.87 (26.04)	6.77 (25.66)	6.66 (25.24)	6.56 (24.86)
		3600	14.20 (53.82)	14.00 (53.06)	13.90 (52.68)	13.80 (52.30)	13.70 (51.92)
H49	1.178 (19.30)	1200	5.90 (22.36)	5.67 (21.49)	5.56 (21.07)	5.44 (20.61)	5.33 (20.20)
		1800	8.85 (33.54)	8.62 (32.67)	8.51 (32.25)	8.39 (31.80)	8.28 (31.38)
		3600	17.70 (67.08)	17.50 (66.33)	17.40 (65.95)	17.30 (65.57)	17.20 (65.19)
H62	1.473 (24.14)	1200	7.39 (28.01)	7.13 (27.02)	7.00 (26.53)	6.88 (26.08)	6.75 (25.58)
		1800	11.10 (42.07)	10.81 (40.97)	10.70 (40.55)	10.60 (40.17)	10.40 (39.42)
		3600	22.20 (84.14)	22.00 (83.38)	21.90 (83.00)	21.80 (82.62)	21.70 (82.24)
H77	1.842 (30.18)	1200	9.23 (34.98)	8.95 (33.92)	8.81 (33.39)	8.67 (32.86)	---
		1800	13.90 (52.68)	13.60 (51.54)	13.40 (50.79)	13.30 (50.41)	---
		3600	27.70 (104.98)	27.50 (104.23)	27.40 (103.85)	27.20 (103.09)	---
H90	2.227 (36.50)	1200	11.20 (42.45)	10.90 (41.31)	10.80 (40.93)	---	---
		1800	16.70 (63.29)	16.50 (62.54)	16.30 (61.78)	---	---
		3600	33.50 (126.97)	33.20 (125.83)	33.10 (125.45)	---	---

Performance Data

Based On Oil Temperature of 120°F (49°C)
(100 SSU) Atmospheric Inlet

H25/H31 Horsepower/Speed

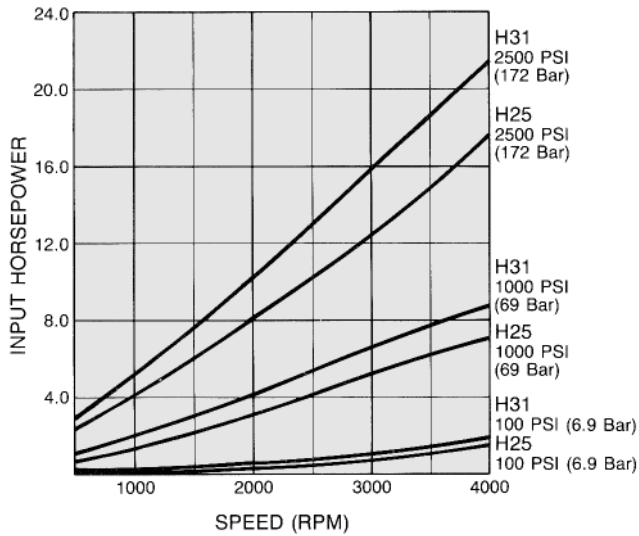

H25/H31 Flow/Speed

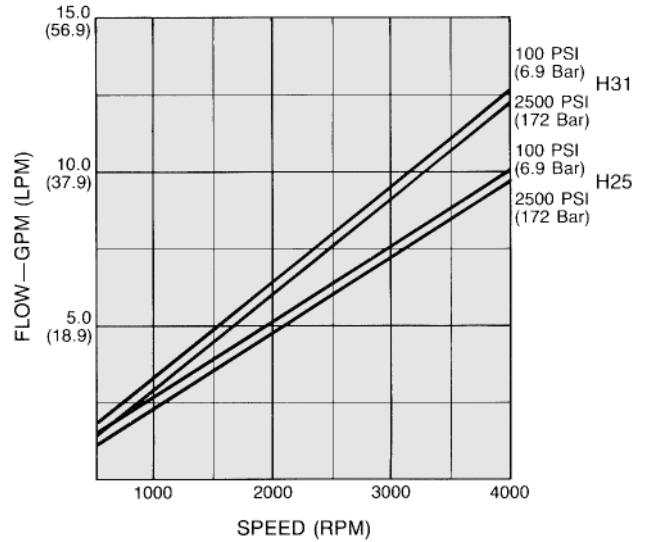

H39/H49 Horsepower/Speed

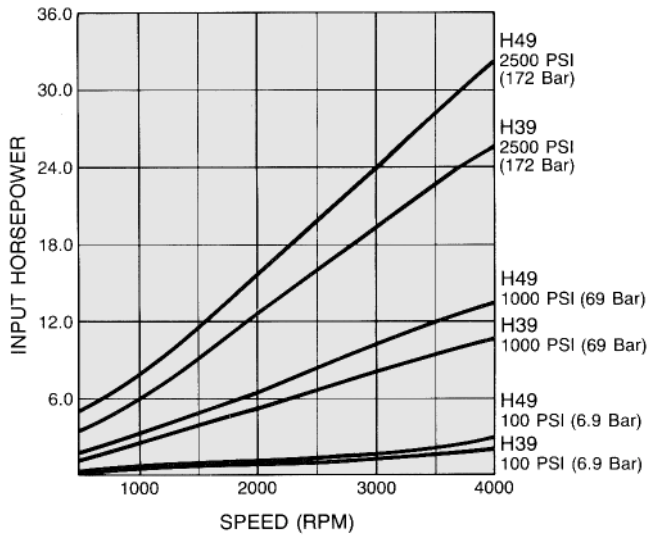

H39/H49 Flow/Speed

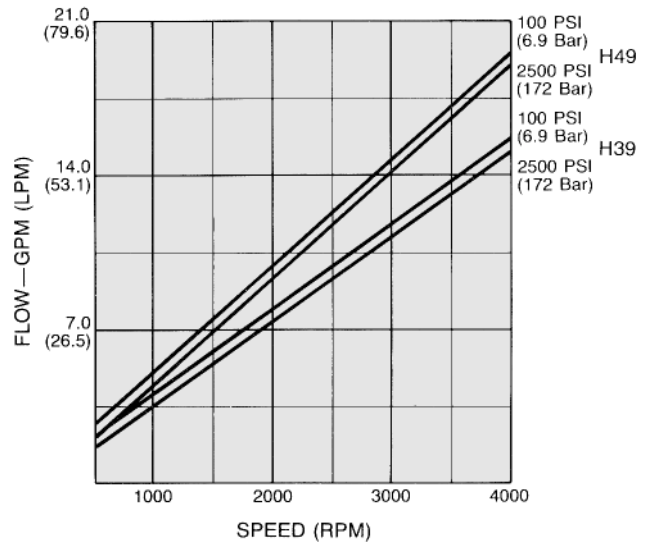

Performance Data

Based On Oil Temperature of 120°F (49°C)
 (100 SSU) Atmospheric Inlet

H62/H77 Horsepower/Speed

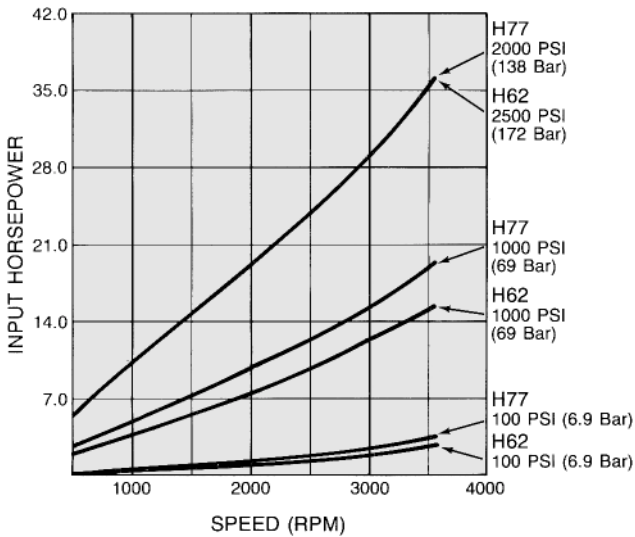

H62/H77 Flow/Speed

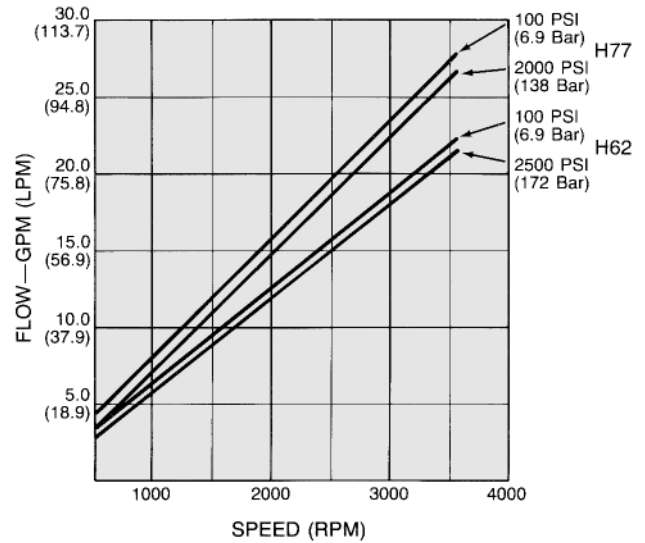

H90 Horsepower/Speed

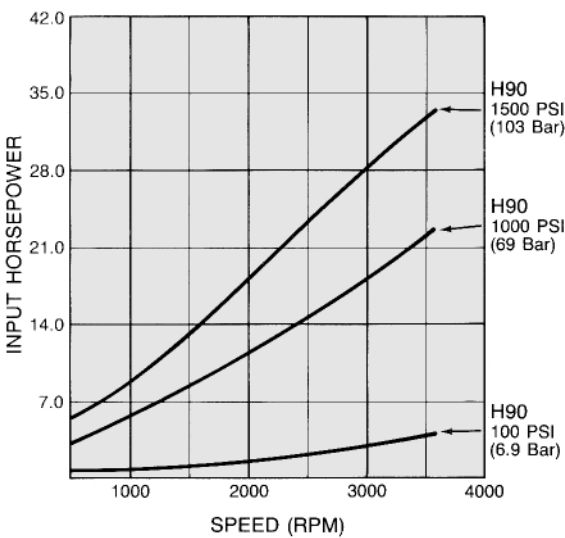

H90 Flow/Speed

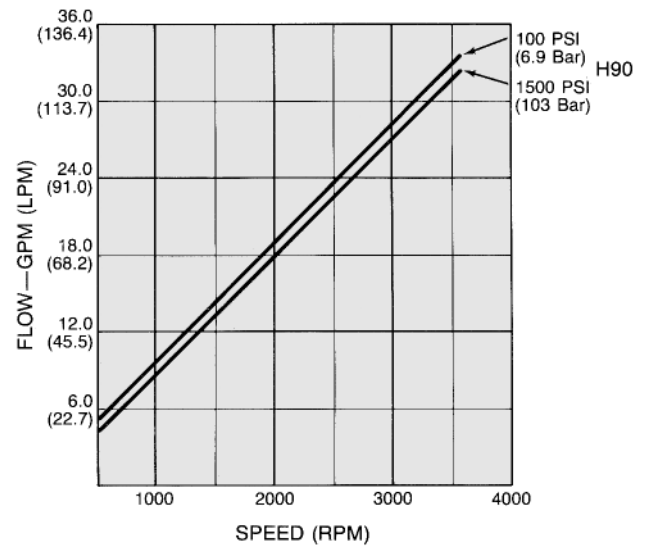

Dimensions – 2-Bolt Mounting

Clockwise rotation and “A” shaft shown
 (Port locations reverse for CCW rotation.)

Dimensions: Inches (mm)

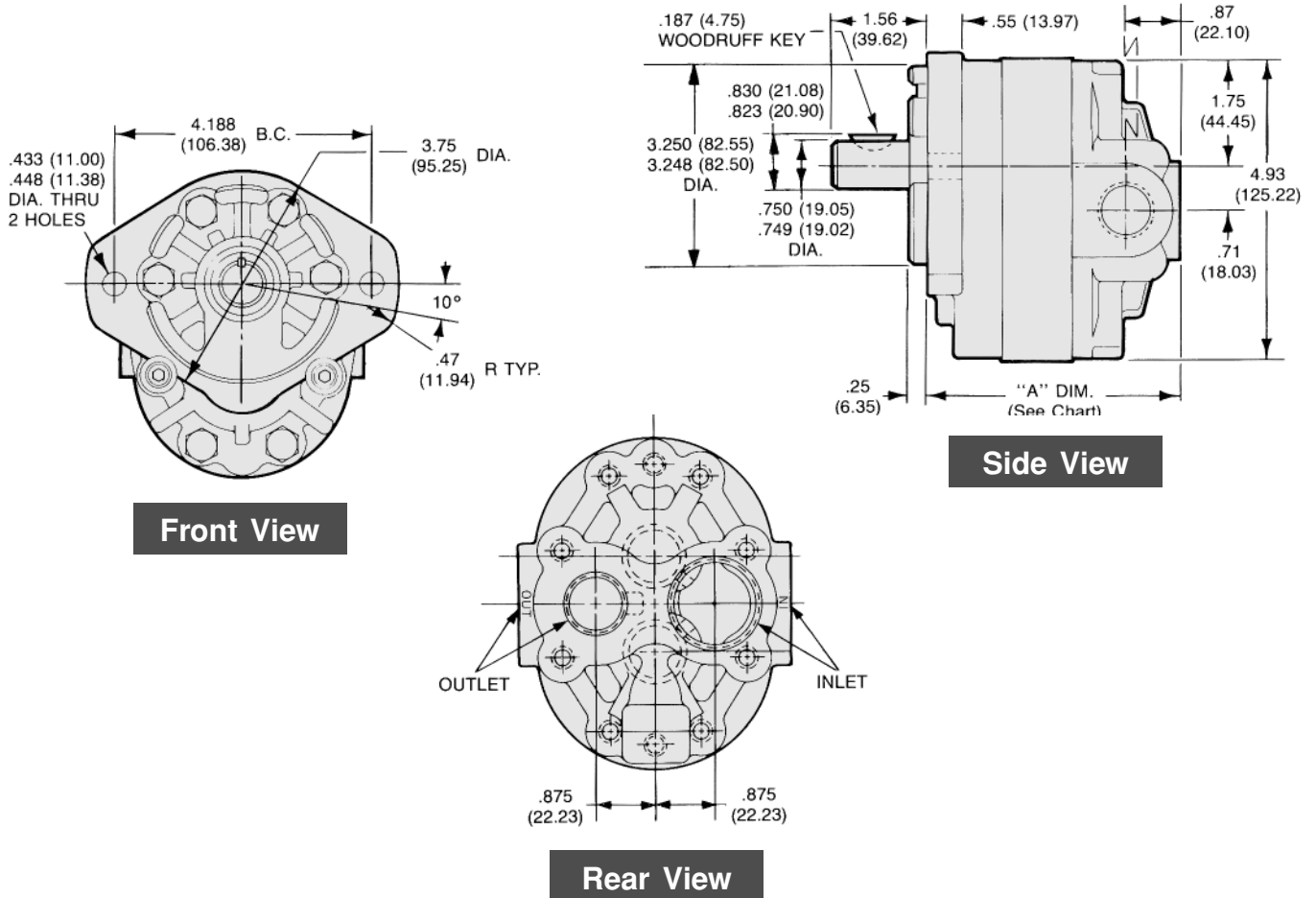

“A” Dimensions: Inches (mm)

Cover	H20	H25	H31	H39	H49	H62	H77	H90
A	3.34 (84.84)	3.43 (87.12)	3.54 (89.92)	3.68 (93.47)	3.86 (98.04)	4.08 (103.63)	4.63 (117.60)	4.92 (124.97)

Cover Option

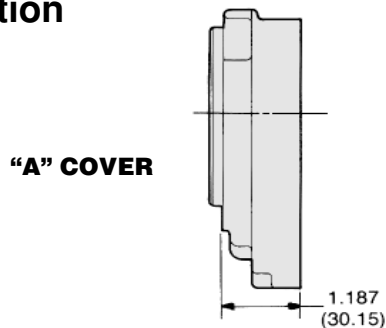

Dimensions – 2-Bolt Mounting

Series with built-in relief valve and flow divider

Dimensions: Inches (mm)

Clockwise rotation and "A" shaft shown
 (Port locations reverse for CCW rotation.)

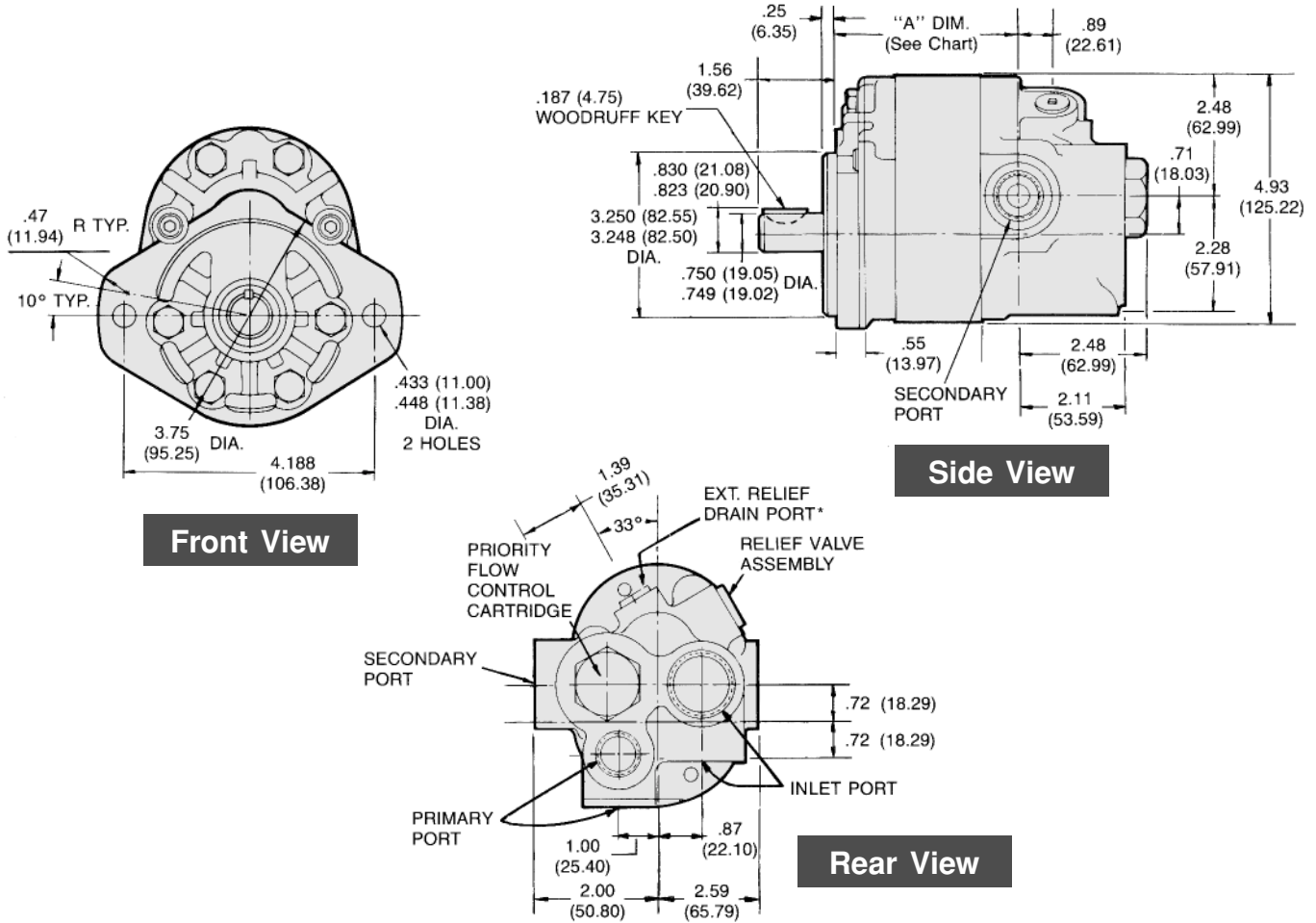

"A" Dimensions: Inches (mm)

Cover	H20	H25	H31	H39	H49	H62	H77	H90
A	2.43 (61.72)	2.52 (64.01)	2.64 (67.06)	2.77 (70.36)	2.95 (74.93)	3.18 (80.77)	3.45 (87.63)	3.75 (95.25)

Circuit Variations

"A" Circuit Schematic

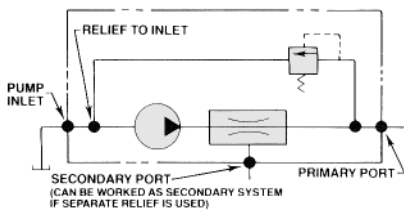

"B" Circuit Schematic*

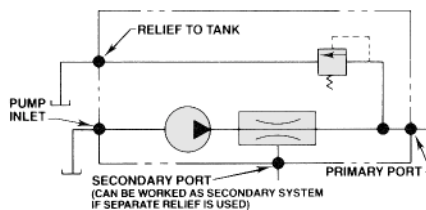

"D" Circuit Schematic*

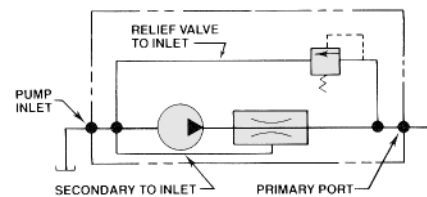

*NOTE: "D" Circuit: Relief valve flow and flow divider secondary flow return to pump inlet internally - primarily used in "on-road" equipment power steering. Relief drain port for "B" variation 9/16"-18 UNF-2B SAE Straight Thread.

Dimensions – Drive Shaft Configurations

Dimensions: Inches (mm)

"T" Shaft

- 3/4" Dia. 11 – tooth spline
- Flat root side fit
- Diametral pitch – 16/32
- Pressure angle – 30°
- No. of teeth – 11

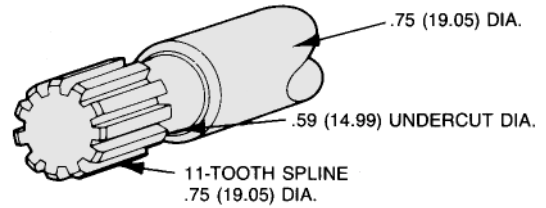
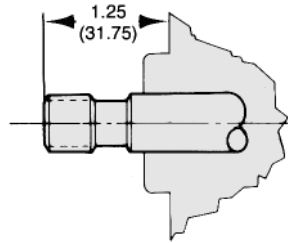

"B" Shaft

- 5/8" dia. 9-tooth spline
- Flat root side fit
- Diametral pitch – 16/32
- Pressure angle – 30°
- No. of teeth – 9

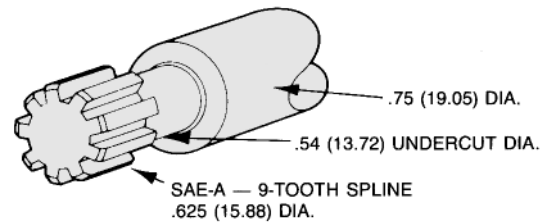
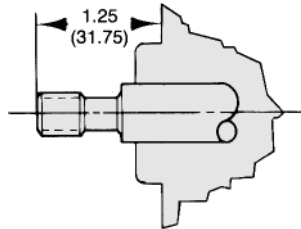

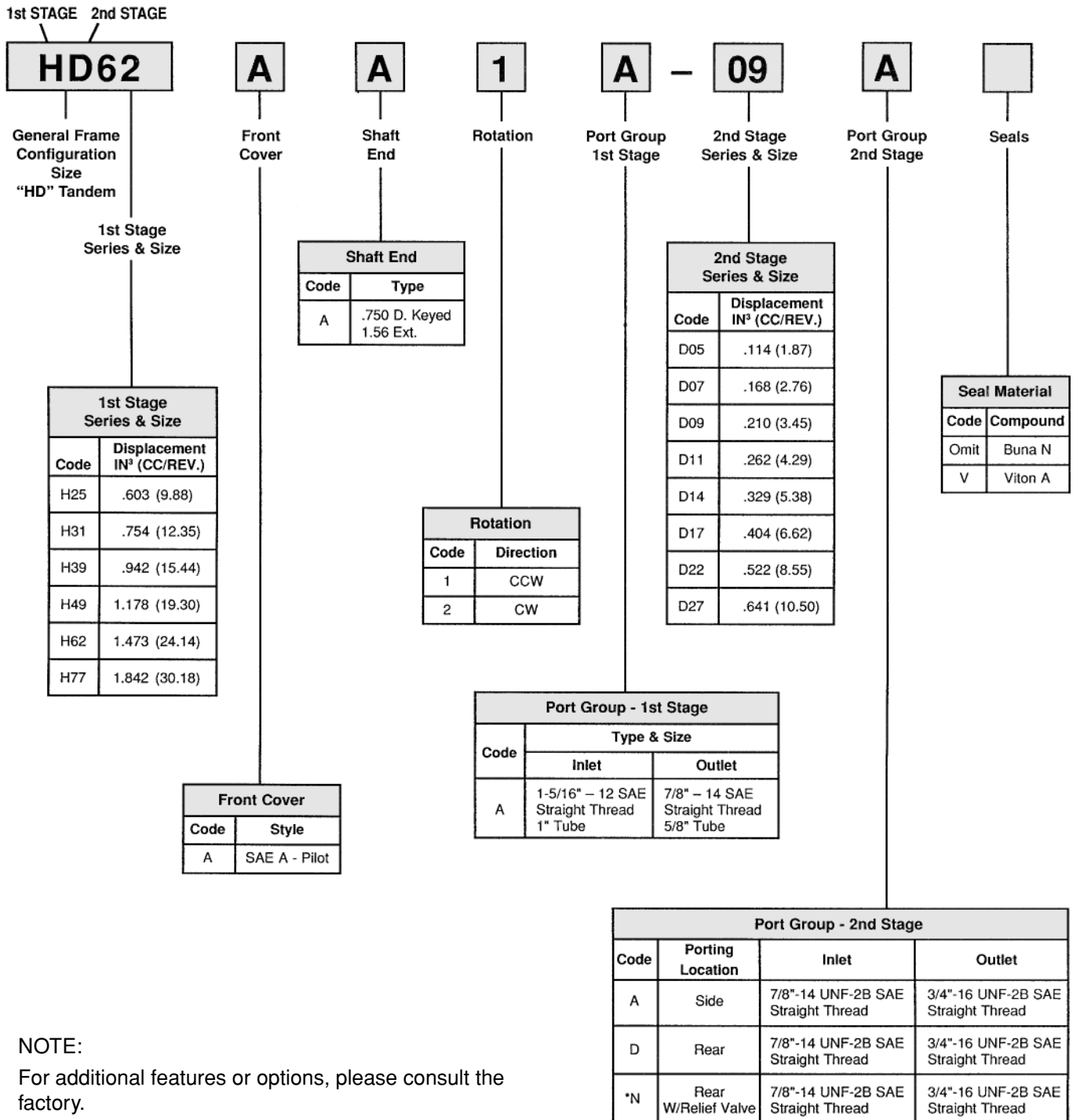

NOTE:
 For additional features or options, please consult the factory.

* Relief valve limits rear pump pressure only. Specify pressure setting at end of model code. (PSI + 10, I.E. 1750 PSI = 175)

Performance Data

Series HD Fixed Displacement, Tandem Pump

Features

- Integral pressure-loaded pump design
- Individual inlet & outlet ports for 1st & 2nd stages of pump
- Fluids common/intermix between 1st & 2nd stages of pump.
- "H" series front cover mount - SAE "A" 2-Bolt
- Efficient at high-pressure operation
- Optional built-in relief - 2nd stage pump

Specifications

Flow Ratings:

See appropriate specification chart.

Pressure Ratings:

See appropriate specification chart.

Speed Ratings:

Minimum: 500 RPM

Maximum: Maximum rated speed of the larger displacement of the two pumps.

See appropriate specification chart for this data.

Torque:

- Combined: 800 in. lb. maximum total continuous duty
- 950 in. lb. maximum total intermittent duty
- 2nd Stage pump cannot exceed 260 in. lb.

For additional information, see the Performance Data chart on page 26.

Housing Material:

Die-cast aluminum



Schematic Symbol

(Basic Pump)

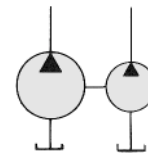

Installation Data

Inlet Conditions:

10 in. hg. max. vacuum condition (At 1200 RPM)

5 in. hg. max. vacuum condition (At 3000 RPM)

20 PSI (1.4 Bar) max. positive pressure

Operating Temperature Range:

-40°F to 185°F (-40°C to 85°C)

Filtration:

Maintain SAE Class 4

Installation Note:

See page 28 for specific recommendations pertaining to system cleanliness, fluids, start-up, inlet conditions, shaft alignment, and other important factors relative to the proper installation and use of these pumps.

Performance Data

	Model	In. Lb. Torque Per 1000 PSI	Maximum Allowable	
			PSI	RPM
FIRST STAGE	H25	121	2500	4000
	H31	152	2500	4000
	H39	190	2500	4000
	H49	237	2500	4000
	H62	296	2250	3600
	H77	372	2000	3600
SECOND STAGE	D05	23	2500	4000
	D07	34	2500	4000
	D09	42	2500	4000
	D11	53	2500	4000
	D14	66	2500	4000
	D17	81	2500	4000
	D22	105	2250	4000
	D27	129	2000	3000

Combined First and Second stage torque cannot exceed:

800 in. lb. Total continuous duty

950 in. lb. Total intermittent duty

Second stage torque cannot exceed 260 in. lb.

Example:

H39 @ 2500 PSI = 190 in. lb. x 2.5/1000 PSI = 475 in. lb. torque

D17 @ 2500 PSI = 81 in. lb. x 2.5/1000 PSI = 203 in. lb. torque

678 in. lb. total torque

Performance Data

Dimensions: Inches (mm)

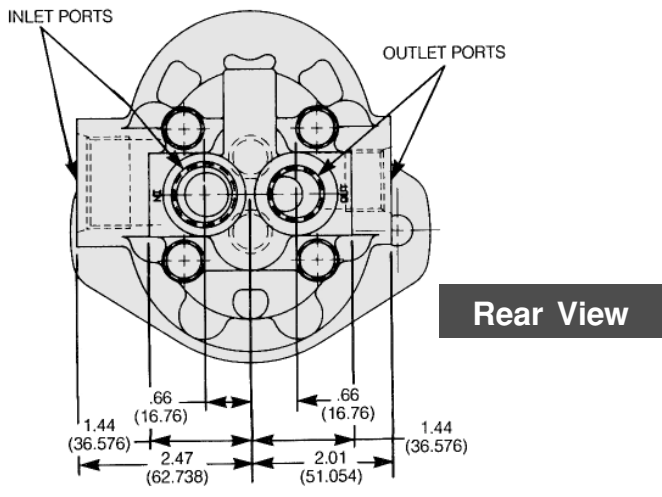
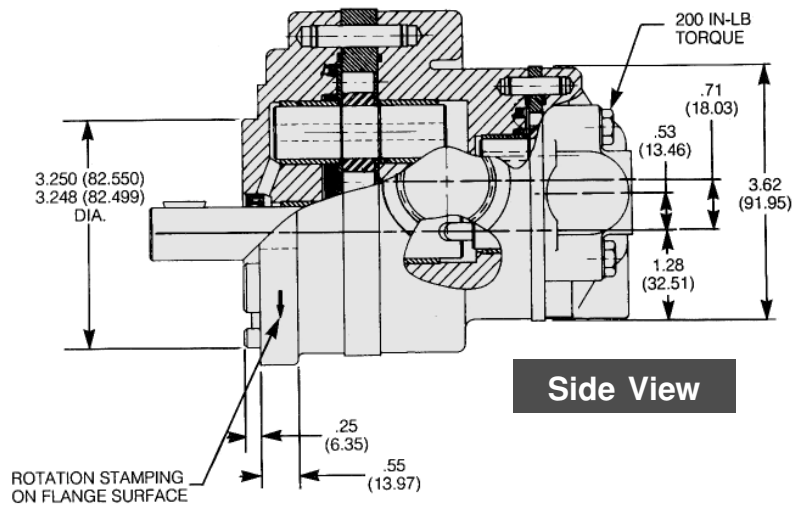
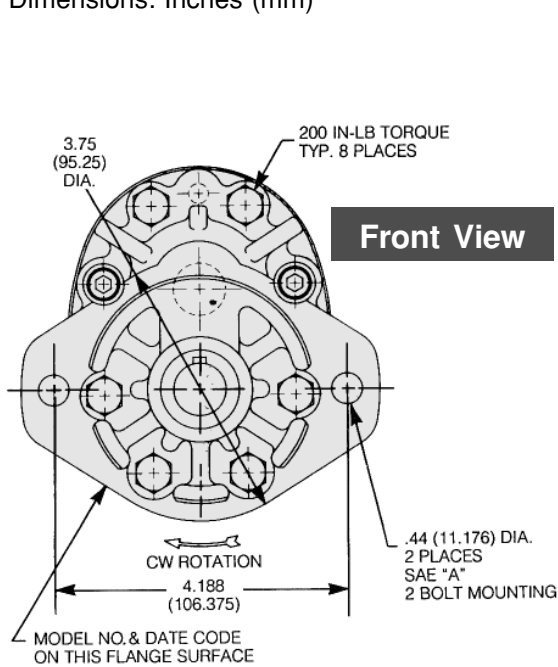

H-Pump Size	DIM "A"	D-Pump Size	DIM "B"
25	2.67 (67.818)	05	2.66 (67.564)
31	2.78 (70.612)	.07	2.77 (70.358)
39	2.92 (74.168)	09	2.81 (71.374)
49	3.10 (78.740)	11	2.89 (73.406)
62	3.32 (84.328)	14	3.01 (76.454)
77	3.60 (91.440)	17	3.13 (79.502)
		22	3.33 (84.582)
		27	3.52 (89.408)

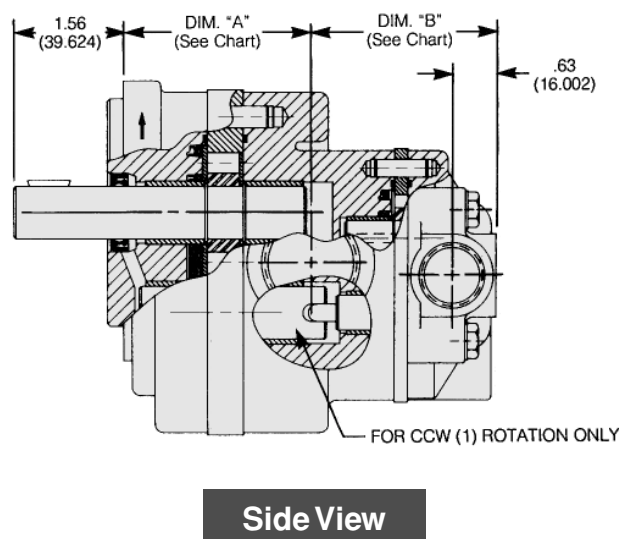
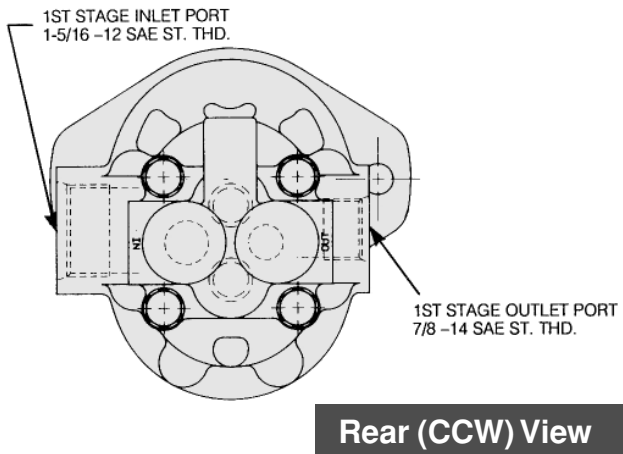

Fluid Recommendations

Use premium-quality hydraulic fluid with operating viscosity range of 80-1000 SSU. The maximum start-up viscosity is 4000 SSU. The fluid should have maximum anti-wear properties, rust and oxidation treatment.

Filtration

For maximum pump and system component life, the system should be protected from contamination at a level not to exceed 125 particles greater than 10 microns per milliliter of fluid (SAE Class 4).

Fluid Compatibility

- Petroleum-based fluid
- Water glycols
- Water emulsions
- Transmission fluid
- Mineral oil fluid

NOTE: All data in this catalog are based on petroleum-based fluid. Pump pressure reduced by 1/2 of specified rating; pump speed rating, reduced by 1000 RPM from specified rating and "DU" bushings must be used when pump operates on water glycols and water emulsions. Consult the factory for special fluids.

Start-Up

On any start-up, where the pump suction line is empty of fluid, the circuit should be open to permit priming.

Inlet Conditions

Conditioning should not exceed 10 in. Hg. at 1800 RPM or 5 in. Hg. at pump maximum rated RPM. Inlet positive pressure should not exceed 20 PSI (1.4 Bar) maximum.

Shaft Rotation And Line Up

Pump and motor shaft alignment must be within .007 inches total indicator reading. Please follow the coupling manufacturer's recommended installation instructions to prevent end thrust on the pump shaft. Turn the pump by hand to assure freedom of rotation. The pump and motor must be on a rigid base.

The coupling should be sized to absorb the peak horsepower generated.

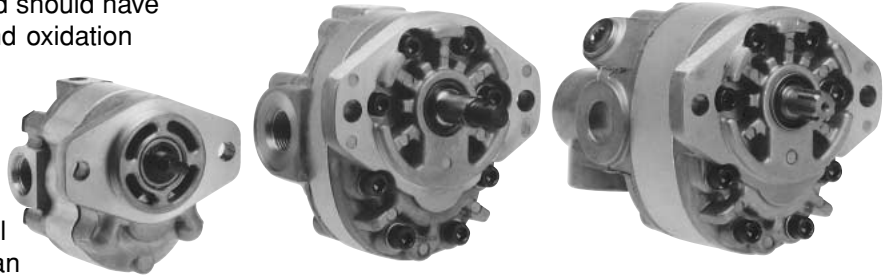

Installation And Mounting

The mounting position is not restricted.

Special Installations

Consult your Parker representative for any application requiring the following:

- Pressure above rated
- Drive speed above maximum
- Indirect drive
- Fluids other than those specified
- Fluid temperature above 185° F. (85° C.).

Instructions for Reversing Gear Pump Rotation

The basic tools needed are a vise, preferably with soft jaws, a torque wrench, a thin screwdriver, a small hone stone, a ratchet and a paper clip. The "D" series will require a 1-1/2" socket; the "H" series an additional 1/4" hex head driver. It is also recommended that you have extra heat shields and gaskets on hand. Part numbers are 655287 and 655288 for the "HD" series; 656942 and 656943 for "H" series.

To change rotation, hold the pump by the rear cover with the drive shaft pointing up. Remove all the bolts. The "HD" series will have four hex heads, and the "H" series will have six hex and two alien heads. For future reference, it would be helpful to scribe a line down the outlet side of the pump. If you choose not to mark it, the outlet port is usually the smallest.

If the pump has a key-type shaft, remove the key and hone down any burrs that may be on the shaft. This is important as the next step will be to lift off the front cover, and any sharp edges could possibly damage the front seal or bearing.

After the front cover is off, note the position of the little vent hole in the bronze wear plate, which should have come off with the front cover. The parts underneath also have a similar vent hole.

Remove in order, the wear plate, the heat shield, the gasket, and the V-seal. To facilitate this, make a small hook with a paper clip and lift the part high enough to slip a screwdriver under it and carefully pry up. Please note that the heat shield, in particular, is very brittle and may crack if bent.

After removing these four parts, reinstall the V-seal with the lips down in the front cover so that the vent hole is on the opposite side across from the reference mark. Use the screwdriver to seat it completely. Next, install the gasket, heat shield, and wear plate; again with the vent hole in line with that of the V-seal. The wear plate should be almost flush with the surface of the front cover.

Remove the center section and note the notch cut on the inside. This will be installed in line and next to the vent hole in the wear plate. The dowel pins used to locate the center section may be removed temporarily to facilitate sliding the center section over the gear assemblies. Be careful not to pinch the O-ring between the front cover and center section. If it doesn't want to stay in place, it can be "glued" using heavy grease.

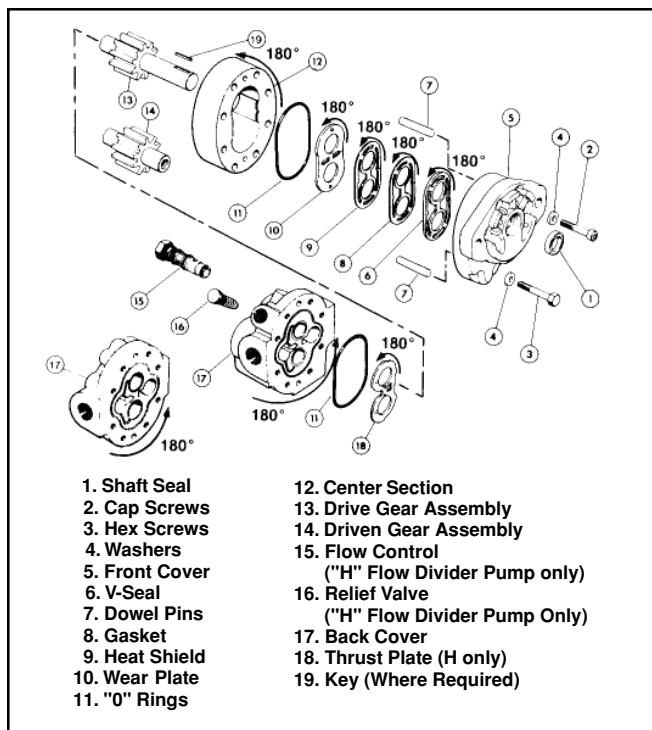

If the pump is an "H" series, install the thrust plate into the center section, orienting the side with the bar in line with the vent hole, ensuring that the bronze side faces the gears.

The rear cover is installed with the outlet side in line with the vent hole. The outlet side will be marked or can be identified by the smaller, internal cavity. As when installing the center section, be careful not to pinch the O-ring seal.

The line that was originally scribed on the side should now be located at 180° on both the rear cover and center section from that on the front cover.

Install the bolts and tighten down by hand. Then, torque to the proper setting, alternating from side to side. The correct torque specifications are 190-210" lbs. for the "D" and "H" series. Reverse or remove the rotation arrow originally stamped on the mounting flange.

Testing Procedure

After the pump has been reinstalled, run for 2-3 minutes before pressurizing. Try to apply pressure gradually for an additional five minutes, but do not pressurize for longer than 5 seconds at a time.

Offer of Sale

The items described in this document and other documents or descriptions provided by Parker Hannifin Corporation, its subsidiaries and its authorized distributors are hereby offered for sale at prices to be established by Parker Hannifin Corporation, its subsidiaries and its authorized distributors. This offer and its acceptance by any customer ("Buyer") shall be governed by all of the following Terms and Conditions. Buyer's order for any such items, when communicated to Parker Hannifin Corporation, its subsidiary or an authorized distributor ("Seller") verbally or in writing, shall constitute acceptance of this offer.

1. Terms and Conditions of Sale: All descriptions, quotations, proposals, offers, acknowledgments, acceptances and sales of Seller's products are subject to and shall be governed exclusively by the terms and conditions stated herein. Buyer's acceptance of any offer to sell is limited to these terms and conditions. Any terms or conditions in addition to, or inconsistent with those stated herein, proposed by Buyer in any acceptance of an offer by Seller, are hereby objected to. No such additional, different or inconsistent terms and conditions shall become part of the contract between Buyer and Seller unless expressly accepted in writing by Seller. Seller's acceptance of any offer to purchase by Buyer is expressly conditional upon Buyer's assent to all the terms and conditions stated herein, including any terms in addition to, or inconsistent with those contained in Buyer's offer. Acceptance of Seller's products shall in all events constitute such assent.

2. Payment: Payment shall be made by Buyer net 30 days from the date of delivery of the items purchased hereunder. Amounts not timely paid shall bear interest at the maximum rate permitted by law for each month or portion thereof that the Buyer is late in making payment. Any claims by Buyer for omissions or shortages in a shipment shall be waived unless Seller receives notice thereof within 30 days after Buyer's receipt of the shipment.

3. Delivery: Unless otherwise provided on the face hereof, delivery shall be made F.O.B. Seller's plant. Regardless of the method of delivery, however, risk of loss shall pass to Buyer upon Seller's delivery to a carrier. Any delivery dates shown are approximate only and Seller shall have no liability for any delays in delivery.

4. Warranty: Seller warrants that the items sold hereunder shall be free from defects in material or workmanship for a period of 18 months from date of shipment from Parker Hannifin Corporation. **THIS WARRANTY COMPRISES THE SOLE AND ENTIRE WARRANTY PERTAINING TO ITEMS PROVIDED HEREUNDER. SELLER MAKES NO OTHER WARRANTY, GUARANTEE, OR REPRESENTATION OF ANY KIND WHATSOEVER. ALL OTHER WARRANTIES, INCLUDING BUT NOT LIMITED TO, MERCHANTABILITY AND FITNESS FOR PURPOSE, WHETHER EXPRESS, IMPLIED, OR ARISING BY OPERATION OF LAW, TRADE USAGE, OR COURSE OF DEALING ARE HEREBY DISCLAIMED.**

NOTWITHSTANDING THE FOREGOING, THERE ARE NO WARRANTIES WHATSOEVER ON ITEMS BUILT OR ACQUIRED WHOLLY OR PARTIALLY, TO BUYER'S DESIGNS OR SPECIFICATIONS.

5. Limitation Of Remedy: SELLER'S LIABILITY ARISING FROM OR IN ANY WAY CONNECTED WITH THE ITEMS SOLD OR THIS CONTRACT SHALL BE LIMITED EXCLUSIVELY TO REPAIR OR REPLACEMENT OF THE ITEMS SOLD OR REFUND OF THE PURCHASE PRICE PAID BY BUYER, AT SELLER'S SOLE OPTION. IN NO EVENT SHALL SELLER BE LIABLE FOR ANY INCIDENTAL, CONSEQUENTIAL OR SPECIAL DAMAGES OF ANY KIND OR NATURE WHATSOEVER, INCLUDING BUT NOT LIMITED TO LOST PROFITS ARISING FROM OR IN ANY WAY CONNECTED WITH THIS AGREEMENT OR ITEMS SOLD HEREUNDER, WHETHER ALLEGED TO ARISE FROM BREACH OF CONTRACT, EXPRESS OR IMPLIED WARRANTY, OR IN TORT, INCLUDING WITHOUT LIMITATION, NEGLIGENCE, FAILURE TO WARN OR STRICT LIABILITY.

6. Changes, Reschedules and Cancellations: Buyer may request to modify the designs or specifications for the items sold hereunder as well as the quantities and delivery dates thereof, or may request to cancel all or part of this order, however, no such requested modification or cancellation shall become part of the contract between Buyer and Seller unless accepted by Seller in a written amendment to this Agreement. Acceptance of any such requested modification or cancellation shall be at Seller's discretion, and shall be upon such terms and conditions as Seller may require.

7. Special Tooling: A tooling charge may be imposed for any special tooling, including without limitation, dies, fixtures, molds and patterns, acquired to manufacture items sold pursuant to this contract. Such special tooling shall be and remain Seller's property notwithstanding payment of any charges by Buyer. In no event will Buyer acquire any interest in apparatus belonging to Seller which is utilized in the notwithstanding any charges paid by Buyer. Unless otherwise agreed, Seller shall have the right to alter, discard or otherwise dispose of any special tooling or other property in its sole discretion at any time.

8. Buyer's Property: Any designs, tools, patterns, materials, drawings, confidential information or equipment furnished by Buyer or any other items which become Buyer's property, may be considered obsolete and may be destroyed by Seller after two (2) consecutive years have elapsed without Buyer placing an order for the items which are manufactured using such property, Seller shall not be responsible for any loss or damage to such property while it is in Seller's possession or control.

9. Taxes: Unless otherwise indicated on the face hereof, all prices and charges are exclusive of excise, sales, use, property, occupational or like taxes which may be imposed by any taxing authority upon the manufacture, sale or delivery of the items sold hereunder. If any such taxes must be paid by Seller or if Seller is liable for the collection of such tax, the amount thereof shall be in addition to the amounts for the items sold. Buyer agrees to pay all such taxes or to reimburse Seller therefore upon receipt of its invoice. If Buyer claims exemption from any sales, use or other tax imposed by any taxing authority, Buyer shall save Seller harmless from and against any such tax, together with any interest or penalties thereon which may be assessed if the items are held to be taxable.

10. Indemnity For Infringement of Intellectual Property Rights: Seller shall have no liability for infringement of any patents, trademarks, copyrights, trade dress, trade secrets or similar rights except as provided in this Part 10. Seller will defend and indemnify Buyer against allegations of infringement of U.S. Patents, U.S. Trademarks, copyrights, trade dress and trade secrets (hereinafter 'Intellectual Property Rights'). Seller will defend at its expense and will pay the cost of any settlement or damages awarded in an action brought against Buyer based on an allegation that an item sold pursuant to this contract infringes the Intellectual Property Rights of a third party. Seller's obligation to defend and indemnify Buyer is contingent on Buyer notifying Seller within ten (10) days after Buyer becomes aware of such allegations of infringement, and Seller having sole control over the defense of any allegations or actions including all negotiations for settlement or compromise. If an item sold hereunder is subject to a claim that it infringes the Intellectual Property Rights of a third party, Seller may, at its sole expense and option, procure for Buyer the right to continue using said item, replace or modify said item so as to make it noninfringing, or offer to accept return of said item and return the purchase price less a reasonable allowance for depreciation. Notwithstanding the foregoing, Seller shall have no liability for claims of infringement based on information provided by Buyer, or directed to items delivered hereunder for which the designs are specified in whole or part by Buyer, or infringements resulting from the modification, combination or use in a system of any item sold hereunder. The foregoing provisions of this Part 10 shall constitute Seller's sole and exclusive liability and Buyer's sole and exclusive remedy for infringement of Intellectual Property Rights.

If a claim is based on information provided by Buyer or if the design for an item delivered hereunder is specified in whole or in part by Buyer, Buyer shall defend and indemnify Seller for all costs, expenses or judgments resulting from any claim that such item infringes any patent, trademark, copyright, trade dress, trade secret or any similar right.

11. Force Majeure: Seller does not assume the risk of and shall not be liable for delay or failure to perform any of Seller's obligations by reason of circumstances beyond the reasonable control of Seller (hereinafter 'Events of Force Majeure'). Events of Force Majeure shall include without limitation, accidents, acts of God, strikes or labor disputes, acts, laws, rules or regulations of any government or government agency, fires, floods, delays or failures in delivery of carriers or suppliers, shortages of materials and any other cause beyond Seller's control.

12. Entire Agreement/Governing Law: The terms and conditions set forth herein, together with any amendments, modifications and any different terms or conditions expressly accepted by Seller in writing, shall constitute the entire Agreement concerning the items sold, and there are no oral or other representations or agreements which pertain thereto. This Agreement shall be governed in all respects by the law of the State of Ohio. No actions arising out of the sale of the items sold hereunder or this Agreement may be brought by either party more than two (2) years after the cause of action accrues.

9/91-P



**Commercial
Hydraulics**



Parker Hannifin Corporation
 6035 Parkland Blvd.
 Cleveland, Ohio , US 44124-4141
 Tel: (216) 896-3000
 Fax: (216) 896-4000
 www.parker.com

Parker Hannifin Corporation

About Parker Hannifin Corporation

Parker Hannifin is a leading global motion-control company dedicated to delivering premier customer service. A Fortune 500 corporation listed on the New York Stock Exchange (PH), our components and systems comprise over 1,400 product lines that control motion in some 1,000 industrial and aerospace markets. Parker is the only manufacturer to offer its customers a choice of hydraulic, pneumatic, and electromechanical motion-control solutions. Our Company has the largest distribution network in its field, with over 7,500 distributors serving nearly 400,000 customers worldwide.

Parker's Charter

To be a leading worldwide manufacturer of components and systems for the builders and users of durable goods. More specifically, we will design, market and manufacture products controlling motion, flow and pressure. We will achieve profitable growth through premier customer service.

Product Information

North American customers seeking product information, the location of a nearby distributor, or repair services will receive prompt attention by calling the Parker Product Information Center at our toll-free number: 1-800-C-PARKER (1-800-272-7537). In Europe, call 00800-C-PARKER-H (00800-2727-5374).

The Aerospace Group is a leader in the development, design, manufacture and servicing of control systems and components for aerospace and related high-technology markets, while achieving growth through premier customer service.



The Climate & Industrial Controls Group designs, manufactures and markets system-control and fluid-handling components and systems to refrigeration, air-conditioning and industrial customers worldwide.



The Fluid Connectors Group designs, manufactures and markets rigid and flexible connectors, and associated products used in pneumatic and fluid systems.



The Seal Group designs, manufactures and distributes industrial and commercial sealing devices and related products by providing superior quality and total customer satisfaction.



The Hydraulics Group designs, produces and markets a full spectrum of hydraulic components and systems to builders and users of industrial and mobile machinery and equipment.



The Filtration Group designs, manufactures and markets quality filtration and clarification products, providing customers with the best value, quality, technical support, and global availability.



The Automation Group is a leading supplier of pneumatic and electro-mechanical components and systems to automation customers worldwide.



The Instrumentation Group is a global leader in the design, manufacture and distribution of high-quality critical flow components for worldwide process instrumentation, ultra-high-purity, medical and analytical applications.



Commercial Hydraulics



Parker Hannifin Corporation
Gear Pump Division
1775 Logan Avenue
Youngstown, OH 44501 USA
Tel: (330) 746-8011
Fax: (330) 746-1148
www.parker.com/gearpump

Catalog HY09-D/H/HD/US
8/02 T&M 5M